

Digital Processing Control Amplifier

Operating Instructions

TA-E2000ESD

Warning

Owner's Record

The model and serial numbers are located at the rear. Record the serial number in the space provided below. Refer to these numbers whenever you call upon your Sony dealer regarding this product.

Model No. TA-E2000ESD Serial No. _____

To prevent fire or shock hazard, do not expose the unit to rain or moisture.

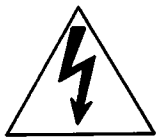
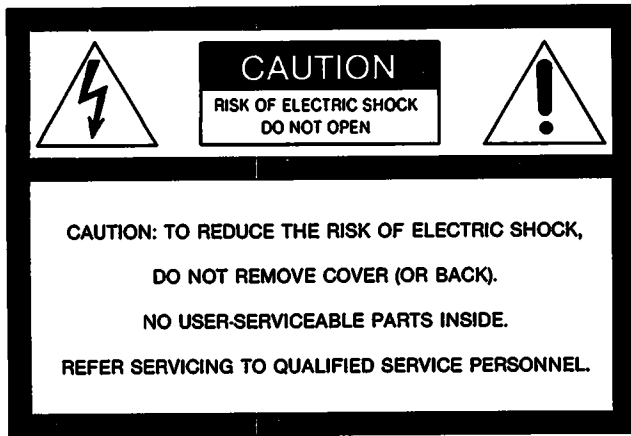

This symbol is intended to alert the user to the presence of uninsulated "dangerous voltage" within the product's enclosure that may be of sufficient magnitude to constitute a risk of electric shock to persons.



This symbol is intended to alert the user to the presence of important operating and maintenance (servicing) instructions in the literature accompanying the appliance.

*The graphical symbols are on the rear enclosure.

For the customers in Canada

CAUTION:

TO PREVENT ELECTRIC SHOCK, DO NOT USE THIS POLARIZED AC PLUG WITH AN EXTENSION CORD, RECEPTACLE OR OTHER OUTLET UNLESS THE BLADES CAN BE FULLY INSERTED TO PREVENT BLADE EXPOSURE.

This apparatus complies with the Class B limits for radio noise emissions set out in Radio Interference Regulations.

INFORMATION

This equipment generates and uses radio frequency energy and if not installed and used properly, that is, in strict accordance with the manufacturer's instructions, may cause interference to radio and television reception. It has been type tested and found to comply with the limits for a Class B computing device in accordance with the specifications in Subpart J of Part 15 of FCC Rules, which are designed to provide reasonable protection against such interference in a residential installation. However, there is no guarantee that interference will not occur in a particular installation. If this equipment does cause interference to radio or television reception, which can be determined by turning the equipment off and on, the user is encouraged to try to correct the interference by one or more of the following measures:

Reorient the receiving antenna

Relocate the equipment with respect to the receiver

Move the equipment away from the receiver

Plug the equipment into a different outlet so that equipment and receiver are on different branch circuits.

If necessary, the user should consult the dealer or an experienced radio/television technician for additional suggestions. The user may find the following booklet prepared by the Federal Communications Commission helpful:

"How to identify and Resolve Ratio-TV Interference Problems". This booklet is available from the U.S. Government Printing Office, Washington DC 20402, Stock No. 004-000-00345-4.

When the control S cord connection causes interference to a TV or tuner, use the supplied ferrite core. Wind the cord around it as close to the TA-E2000ESD as possible. Close the ferrite core.

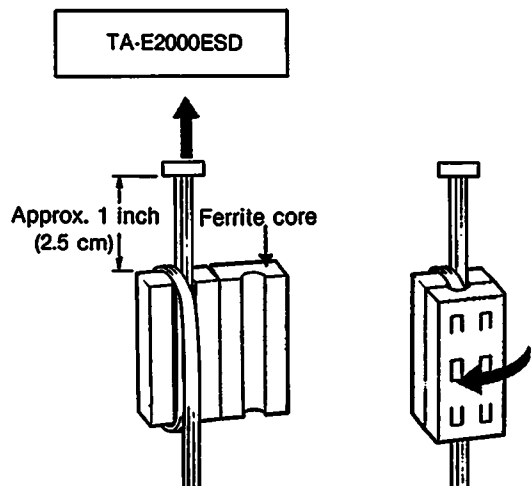

Table of Contents

Introduction		
Overview	4	
Precautions	5	
Chapter 1 Getting Started		
Unpacking	6	
Checking the supplied accessories.....	6	
Removing the side panels.....	6	
Inserting the batteries into the remote commander.	6	
Choosing a good location.....	6	
Hooking up the system.....	7	
Connecting audio equipment.....	7	
Connecting video equipment.....	9	
Connecting power amplifiers	11	
Connecting the remote control system.....	12	
Connecting power cords.....	13	
Functions of controls	14	
Front panel.....	14	
Display.....	17	
Programmable remote commander RM-P2000	18	
Getting ready to enjoy surround effect	20	
Placement of speakers and selecting the Pro Logic mode	20	
Adjusting the speaker volume level	22	
Adjusting the input level.....	24	
Adjusting the delay time of the rear speakers	25	
Chapter 2 Basic Operation		
Listening to/watching program sources	26	
Basic operation.....	26	
Combining the video image with the sound from another program source	27	
Assigning digital audio input to an input select button.....	28	
Enjoying the factory-preset sound fields.....	29	
Characteristics of the sound fields	30	
Recording audio/video program sources	31	
Recording program sources with digital sound effects.....	31	
Chapter 3 Advanced Operation		
What is DSP?.....	32	
Knowing what parameters are adjustable.....	32	
Table of adjustable parameters.....	33	
Creating your own sound fields.....	34	
Simulating the room size.....	34	
Simulating the wall material.....	35	
Simulating the seat position	36	
Adjusting the sub parameters	37	
(Early reflection time, Early reflection level, Reverb time, Effect level, PRO LOGIC DECODER, Separation control)		
Adjusting the digital dynamics controller	40	
Adjusting the digital parametric equalizer	41	
Storing your private setting	43	
Storing your private setting	43	
Calling up the sound field setting.....	44	
Assigning titles.....	45	
Assigning a title to an input select button	45	
Assigning a title to a sound field.....	46	
Recording program sources while listening to/ watching another.....	47	
Using the remote commander	48	
Storing signals.....	48	
Controlling equipment.....	49	
Chapter 4 Additional Information		
Table of factory-preset parameters	50	
Specifications	51	
Block diagram	52	
Messages in the display	53	
Troubleshooting guide.....	54	

Organization of This Manual

This manual is divided into four chapters, starting on page 6: "Getting Started", "Basic Operation", "Advanced Operation" and "Additional Information". "Getting Started" describes the basic connections, the level adjustment procedures and final preparations. "Basic Operation" describes the basic methods of operation. After reading this section, you will be able to take advantage of the basic functions of this amplifier.

"Advanced Operation" describes advanced methods of operation, such as adjusting parameters to tailor the sound field to your personal tastes. "Additional Information" provides technical information, such as specifications, and also provides troubleshooting guide.

Overview

The TA-E2000ESD is a control amplifier with a built-in digital signal processor. You can enjoy various audio and video program sources with this unit.

Digital Surround

- This amplifier electronically reproduces the reflected sound and reverberative sound by using its digital signal processor, and allows you to obtain various acoustic effects.
-  * Dolby Pro Logic Surround allows you to enjoy surround effects as if you were in a movie theater while playing back a video program recorded with Dolby Surround. The Pro Logic directionality emphasis circuitry gives a natural feel to the movement and position of sounds in the video program, making you feel as if you were right in the middle of the action. As all of the Pro Logic circuitry in this unit processes all signals digitally (including automatic input balance), the sensation of the movement and position of sound sources has been greatly enhanced, and channel separation has been greatly improved.

Digital Parametric Equalizer

- The front, center, and rear channels have each been divided into three frequency bands, allowing you to adjust each frequency and level independently; this arrangement makes it possible for you to enjoy equalizer effects in accordance with your own taste and to compensate for differences in sound quality among speakers. (Refer to page 41.)

Digital Dynamics

- The compressor and expander can be used to control the dynamic range.
- The compressor compresses the dynamic range of the program source, allowing you to enjoy dynamic sound even at low input levels.
- The expander eliminates noise in the program source between the pieces of music by using the noise gate effect. (Refer to page 40.)

Preset Memory/User Memory

- Ten sound field programs (combinations of surround, parametric equalizer and dynamics settings) are already stored in memory, allowing you to easily tailor the sound to the current music or listening environment. In addition, you can store up to ten more sound field programs of your own creation. (Refer to page 43.)

Visual Control Center

- Up to a total of seven devices (VCR, laser disc player and TV tuner) can be connected to this amplifier. (Refer to page 9.)
- By using the mixing function, you can combine video images with sound from separate program sources. (Refer to page 27.)
- You can also add titles, such as changing the input selection display to the names of the connected equipment. (Refer to page 45.)

Advanced Pulse D/A Converter

- With the D/A converter, it is possible to directly connect digital output from a laser disc player or DAT deck to this amplifier. (Refer to page 8.) In particular, the design principles of the advanced pulse D/A converter in this amplifier suppress the generation of differential nonlinear distortion and glitches that occur with conventional D/A converters, creating a more natural and warmer sound.

Programmable Remote Commander RM-P2000

- As it is possible to program the remote commander supplied with this amplifier with the signals used by other remote controllers which use infrared rays, you can operate your whole system with this one remote commander.

* Manufactured under license from Dolby Laboratories Licensing Corporation. Additionally licensed under one or more of the following patents: U.S. numbers 3,632,886, 3,746,792, and 3,959,590. Canadian numbers 1,004,603 and 1,037,877. "DOLBY" and the double-D symbol  are trademarks of Dolby Laboratories Licensing Corporation.

Precautions

On safety

- Operate the unit on 120V AC, 60Hz.
- Should any solid object or liquid fall into the cabinet, unplug the unit and have it checked by qualified personnel before operating it any further.
- Unplug the unit from the wall outlet if it is not to be used for an extended period of time. To disconnect the cord, pull it out by grasping the plug. Never pull the cord itself.
- One blade of the plug is wider than the other for the purpose of safety and will fit into the power outlet only one way. If you are unable to insert the plug fully into the outlet, contact your dealer.

On operation

Before making program source connections, be sure to turn the power switch off and unplug the unit.

On cleaning the cabinet

Clean the cabinet, panel and controls with a soft cloth lightly moistened with mild detergent solution. Do not use any type of abrasive pad, scouring powder, or solvent such as alcohol or benzene.

For the customers in the U.S.A.

For detailed safety precautions, see the "IMPORTANT SAFEGUARDS" leaflet.

If you have any question or problem concerning your unit, please consult your nearest Sony dealer.

Unpacking

First, check the supplied accessories and install the batteries in the programmable remote commander.

Checking the Supplied Accessories

After unpacking, check that the following accessories are present.

Remote commander RM-P2000 (1)

Sony battery SUM-3 (NS) (2)

Audio connecting cord (3)

Screw (4)

Ferrite core (1)

Do not throw away the carton and packing material!

It will be an ideal container when transporting the system for repair work, etc.

Removing the Side Panels

You can remove the side panels. When you remove the panels, fix the cabinet with the short screws supplied instead of the screws that were removed. Do not use screws other than those supplied, since doing so might damage the internal circuit boards.

For your safety, disconnect the AC power cord from the wall outlet before proceeding.

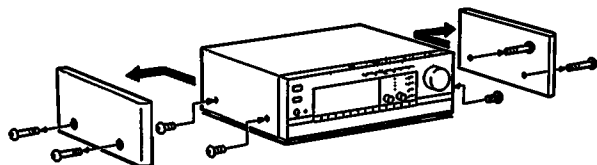

Inserting the Batteries into the Remote Commander

Install the batteries as shown.

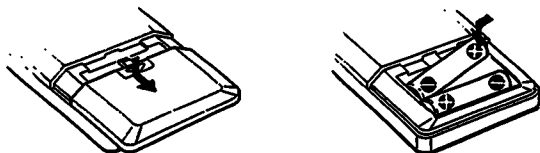

Battery life

Normal operation can be expected about a half year using Sony SUM-3 (NS).

When the batteries are run down, the remote commander will not operate the unit. In this case, replace the batteries with new ones.

Choosing a Good Location

To prevent internal heat buildup in the unit, place the unit in a location with adequate air circulation.

Do not install the unit:

- Near heat sources such as radiators or air ducts.
- In a place subject to direct sunlight, excessive dust, mechanical vibration or shock.

Do not place anything on top of the cabinet.

The top ventilation holes must be unobstructed for the proper operation of the unit and to prolong the life of its components.

Hooking up the System

Connect the unit with other equipment.

Notes on connections

- The cable connectors should be fully inserted into the jacks. Loose connection may cause hum and noise or make the remote commander operation impossible.
- Jacks and plugs of the connection cord are color-coded as follows.

Red jacks and plugs: for the right channel of audio signals

White jacks and plugs: for the left channel of audio signals

Yellow jacks and plugs: for video signals

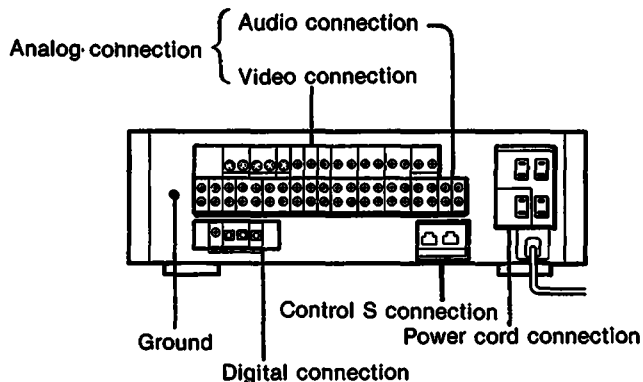

Connecting Audio Equipment

Analog connection

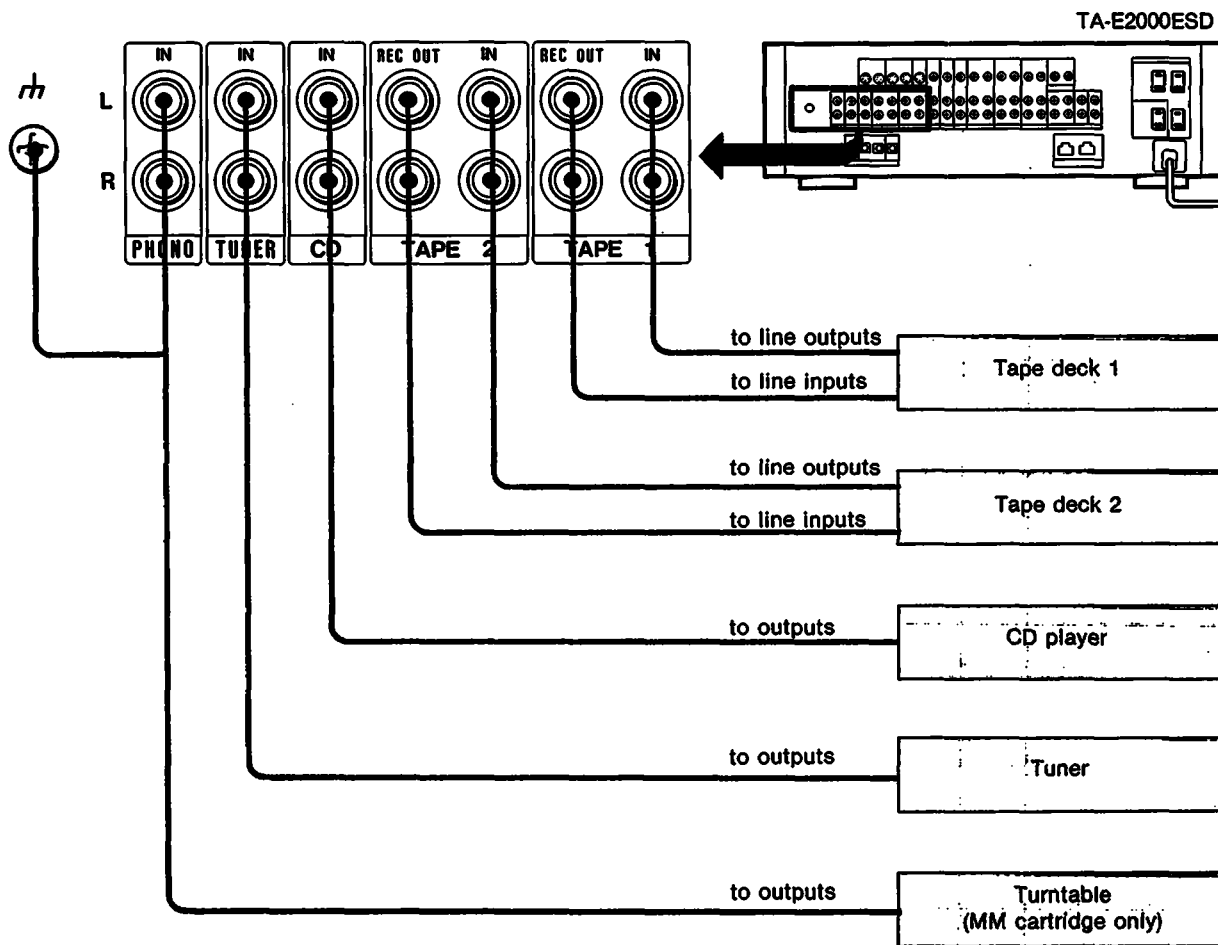

Hooking up the System

Digital connection—Connecting a CD player or DAT deck equipped with digital output

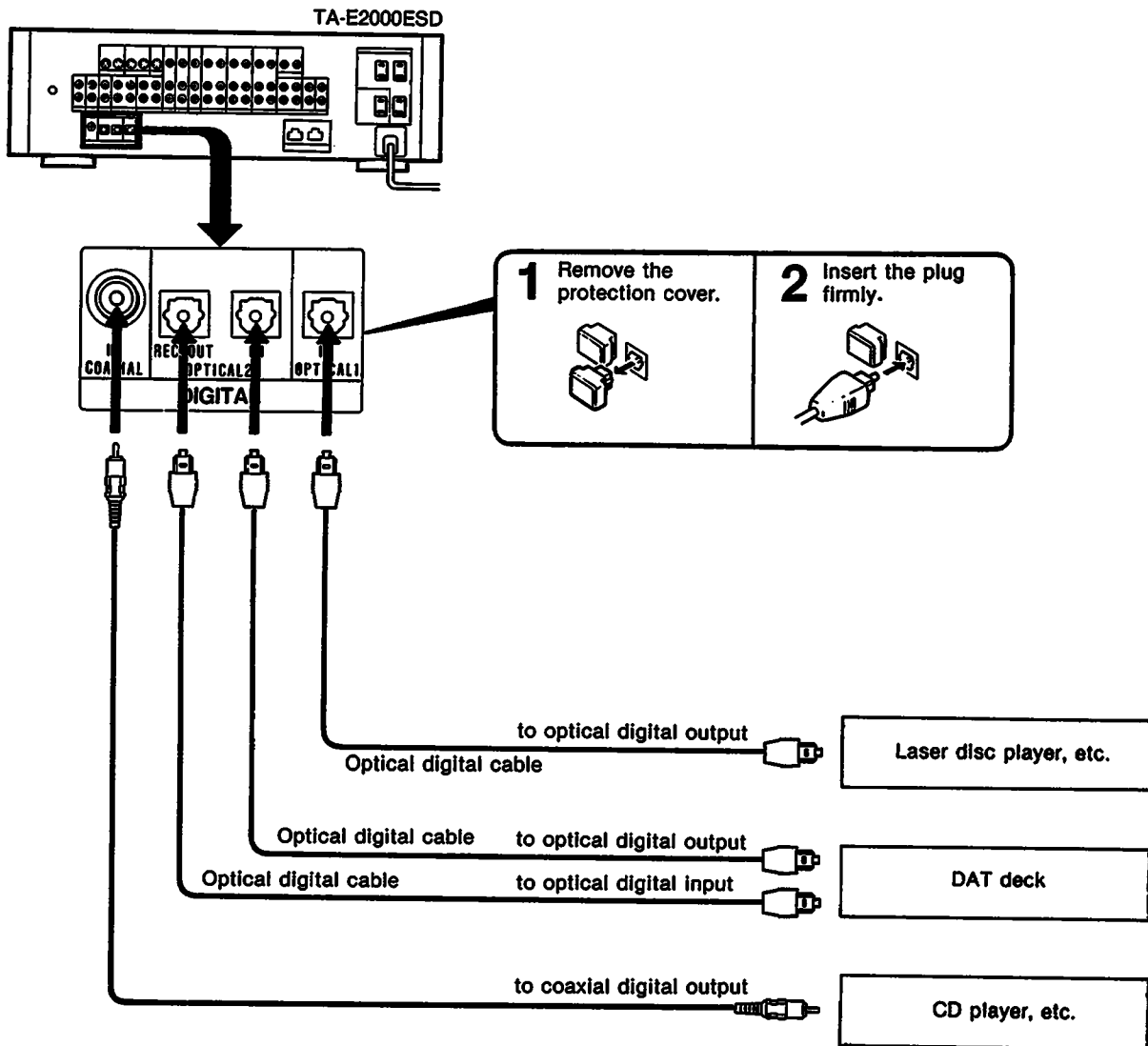

Connecting Video Equipment

Connecting a video equipment which is not equipped with the S connectors

Connecting a video camera recorder

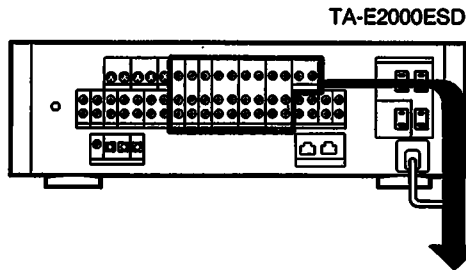

VIDEO 5 INPUT jacks are useful for playing back recordings made with a video camera recorder.

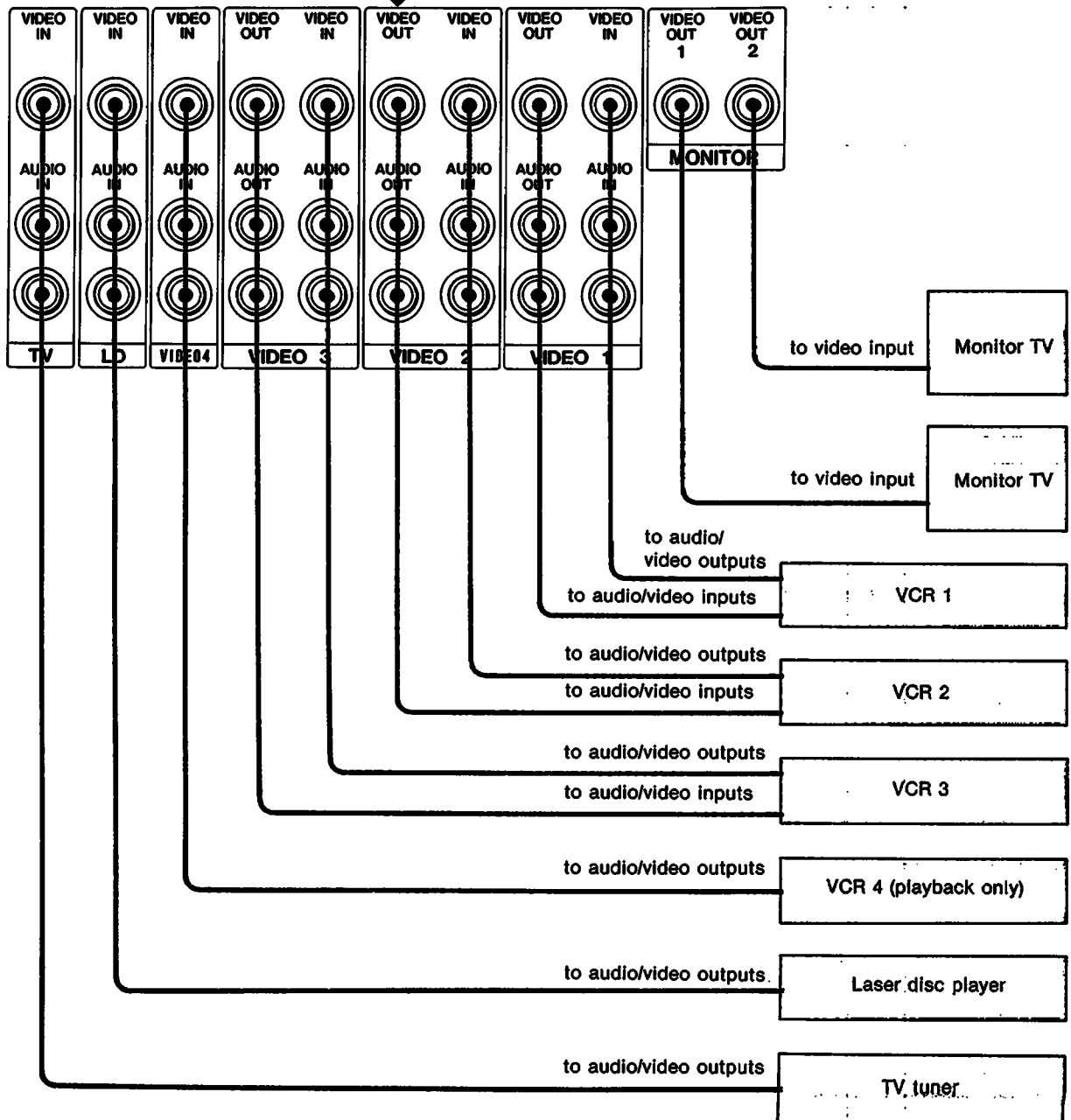

Hooking up the System

Connecting a VCR and monitor TV equipped with the S connectors

Video connections are also possible using the S VIDEO connectors.

Audio connections are the same as those when connecting a VCR without the S VIDEO connectors.

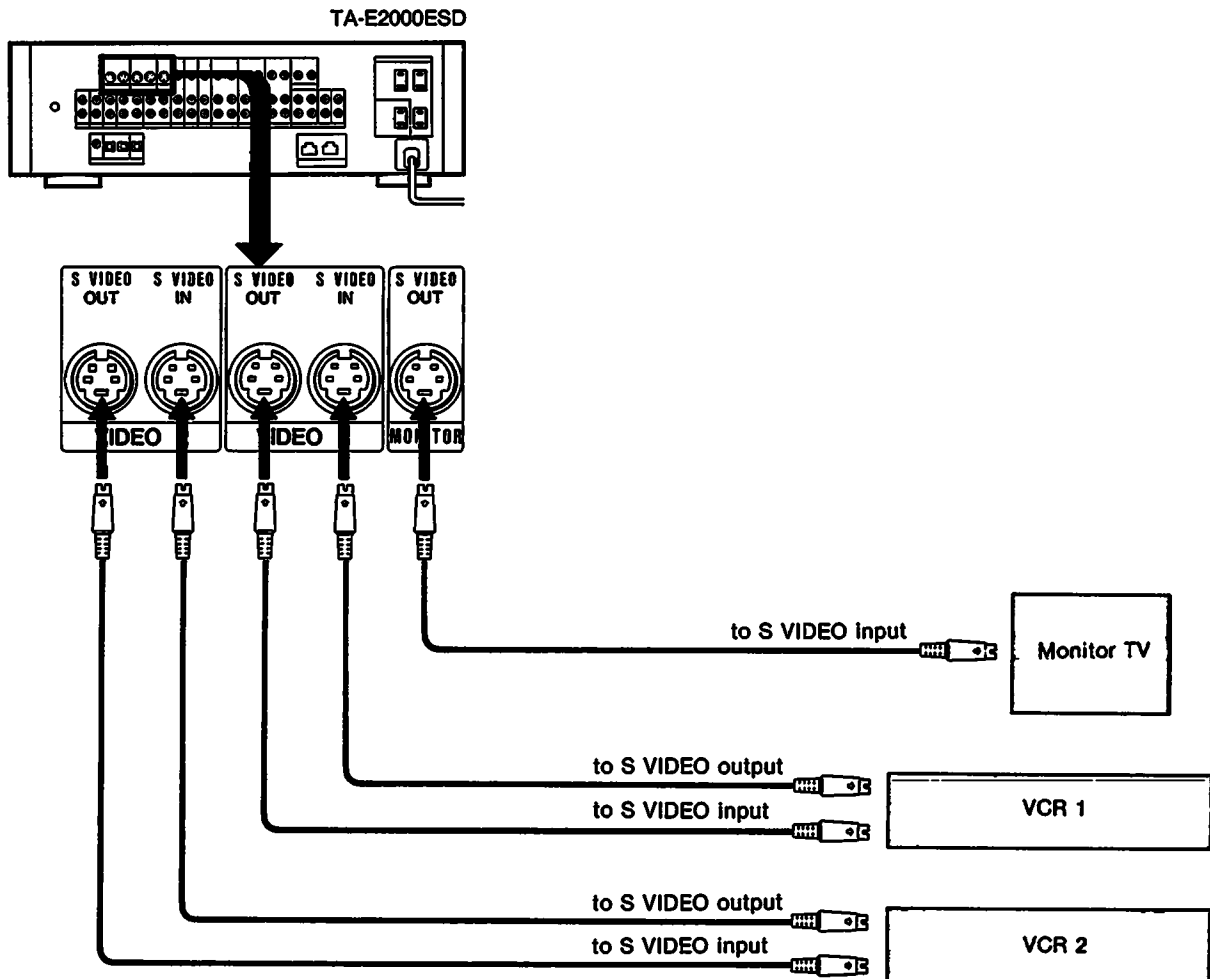

Note

The S VIDEO circuitry and the VIDEO circuitry of this unit are independent of each other. The signals input from the S VIDEO jacks are not output to the VIDEO jacks, and the signals input from the VIDEO jacks are not output to the S VIDEO jacks. Therefore, video dubbing is only possible between the S VIDEO jacks or between the VIDEO jacks.

Connecting Power Amplifiers

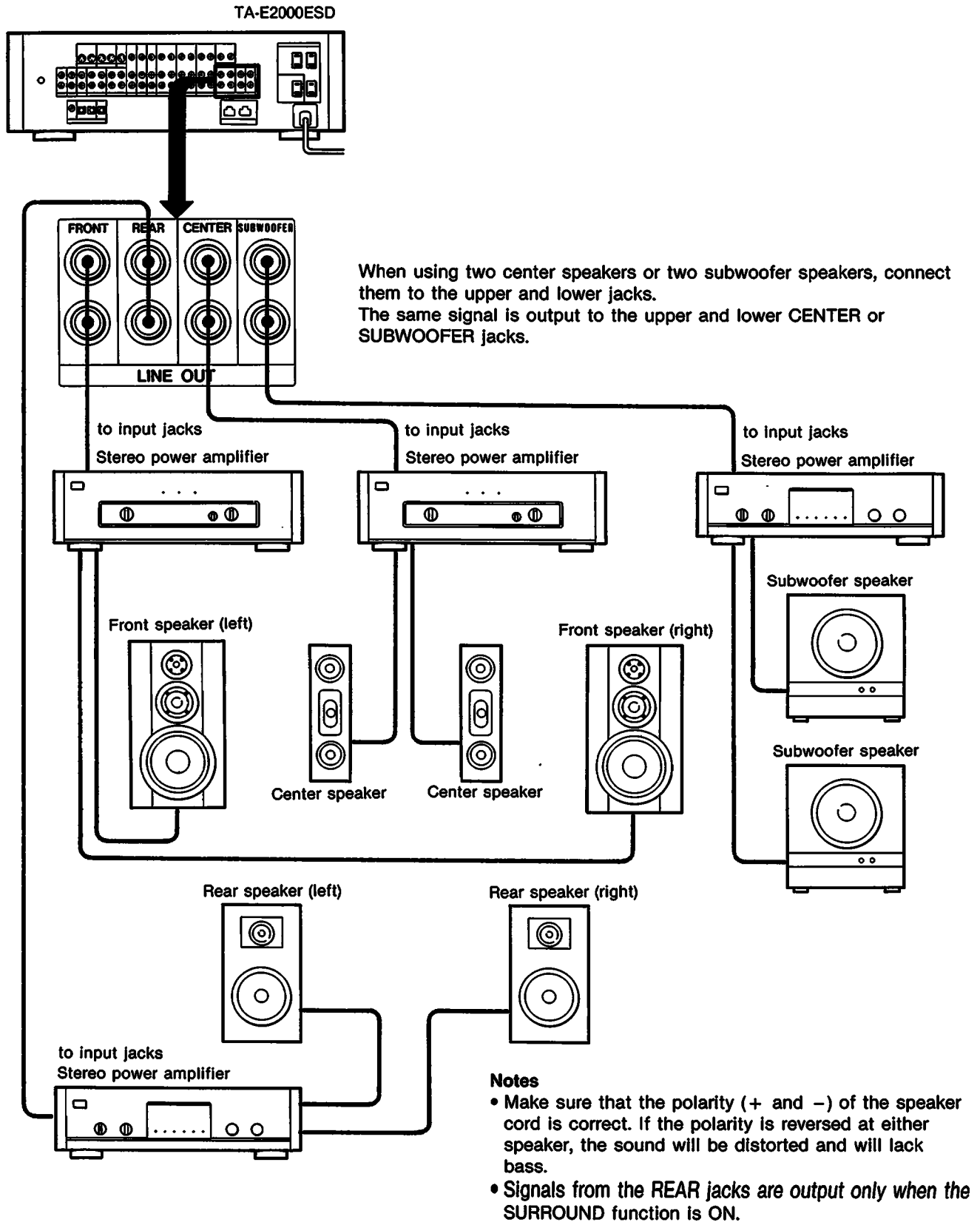

Hooking up the System

When using TV speakers as center speakers
Connect the speakers to the CENTER jacks.

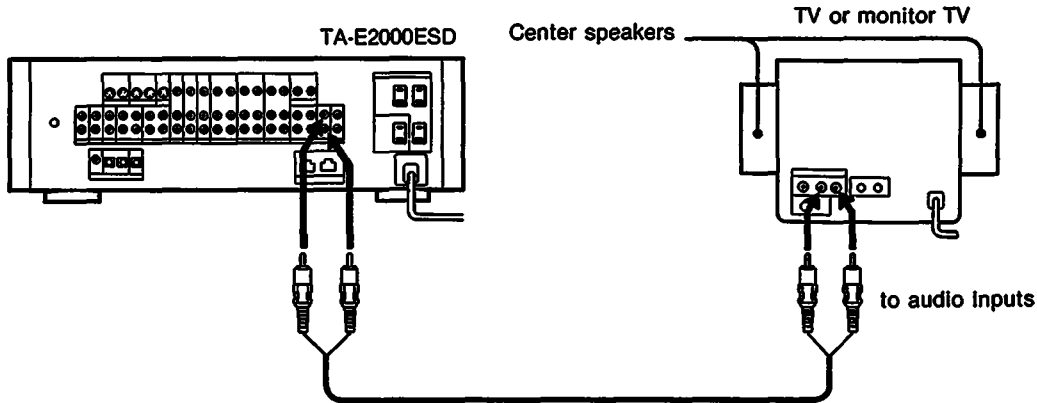

Connecting the Remote Control System

To control other equipment connected to this amplifier with the remote commander, connect the CONTROL S OUT connector and the CONTROL S IN connector of each piece of equipment as illustrated below.

Example of audio connection

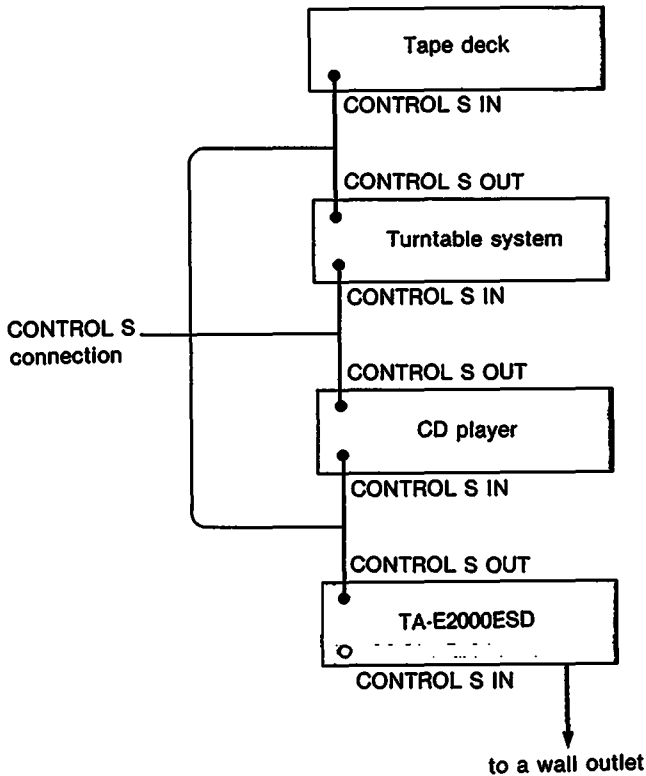

When the control S cord connection causes interference to a TV or tuner, use the supplied ferrite core. Wind the cord around it as close to the TA-E2000ESD as possible. Close the ferrite core.

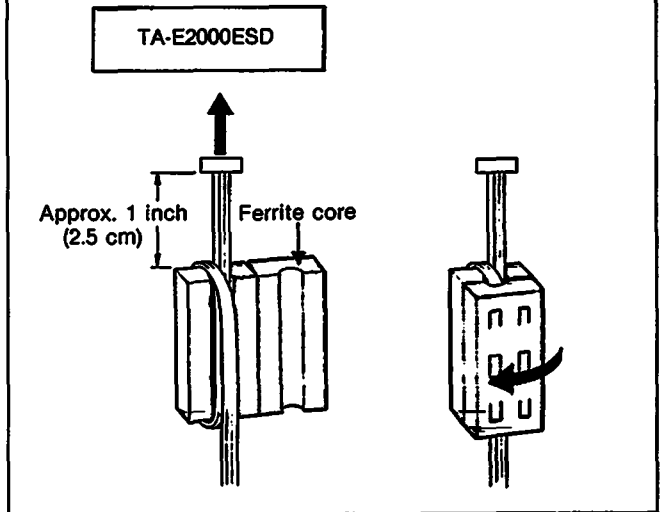

Connecting Power Cords

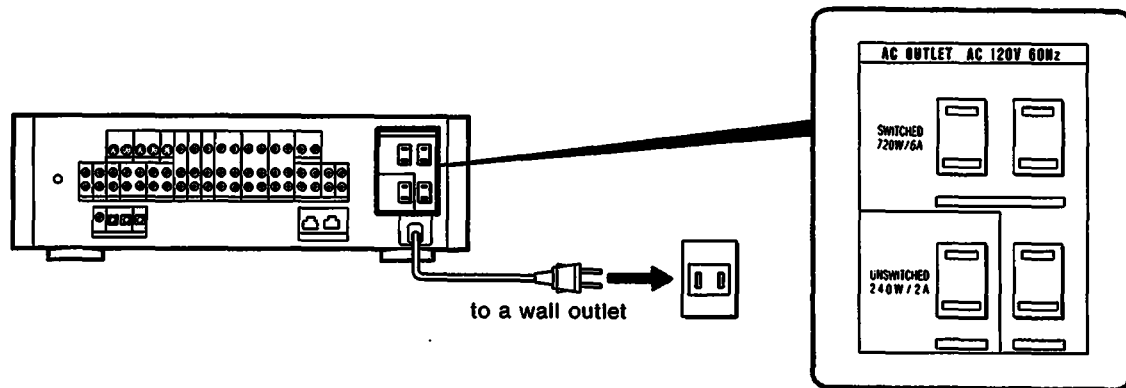

Notes on AC outlets on the rear panel

You can use AC outlets to supply power to other equipment.

SWITCHED outlets: This amplifier supplies power to each equipment plugged into these outlets only when the POWER switch of this amplifier is ON. You can connect up to three components whose total power consumption is less than 720 watts.

UNSWITCHED outlet: Power is always supplied to other equipment plugged into this outlet independently of the POWER switch of this amplifier as long as the power cord of this amplifier is connected to a wall outlet. Power consumption of the other audio equipment should be less than 240 watts.

Caution

Be careful that the total power consumption of equipment connected to the outlets does not exceed 720 or 240 watts for the switched and unswitched outlets, respectively.

Do not connect electrical home appliance such as an electric iron, fan, TV or other high-wattage equipment to these outlets.

Functions of Controls

—Refer to the pages indicated in parentheses for details.

Front Panel

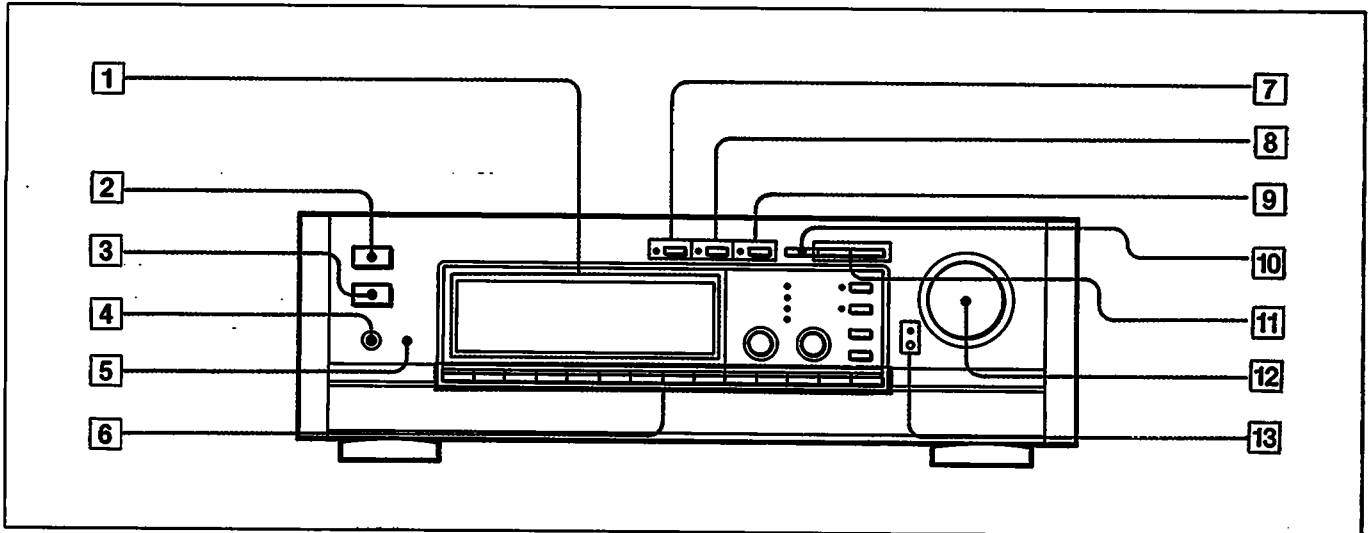

1 Display

2 POWER switch

Press to turn on the amplifier and the equipment connected to the SWITCHED outlets. Press again to turn off.

3 Remote control sensor

4 HEADPHONES Jack

Accepts the stereo phone plug of headphones. The jack outputs the sound of the front speakers only. To listen to the program source only with the headphones, turn off each power amplifier or set the speaker select switch on each amplifier to OFF.

5 DIMMER button (page 32)

Adjusts the brightness of the display to one of three levels. You can also use this button to check which parameter can be adjusted.

6 Input select buttons and MIX button (page 26)

Select the desired program source.

7 PARAMETRIC EQ button and indicator (pages 32 and 41)

Turns on and off the parametric equalizer. When the parametric equalizer is on, the indicator lights.

8 DYNAMICS button and indicator (pages 32 and 40)

Turns on and off the dynamics function. When the dynamics function is on, the indicator lights.

9 SURROUND button and indicator (pages 32 and 34)

Turns on and off the surround function. When the surround function is on, the indicator lights.

10 PRESET/USER button (page 44)

Selects either the sound field preset at the factory or sound field preset by the user.

11 SOUNDFIELD PROGRAM buttons (page 29)

Selects the desired sound field.

12 MASTER VOLUME knob (page 26)

Controls the audio level from LINE OUT and HEADPHONES jacks.

13 SOURCE DIRECT button and indicator (page 31)

Directly outputs the program source sound without passing through the parametric equalizer, dynamics and surround circuitry. Rear and center outputs are disconnected and signals are output from the front and subwoofer. Press the button again to release. In EFFECT REC mode, if the SOURCE DIRECT button is pressed, EFFECT REC mode will be released.

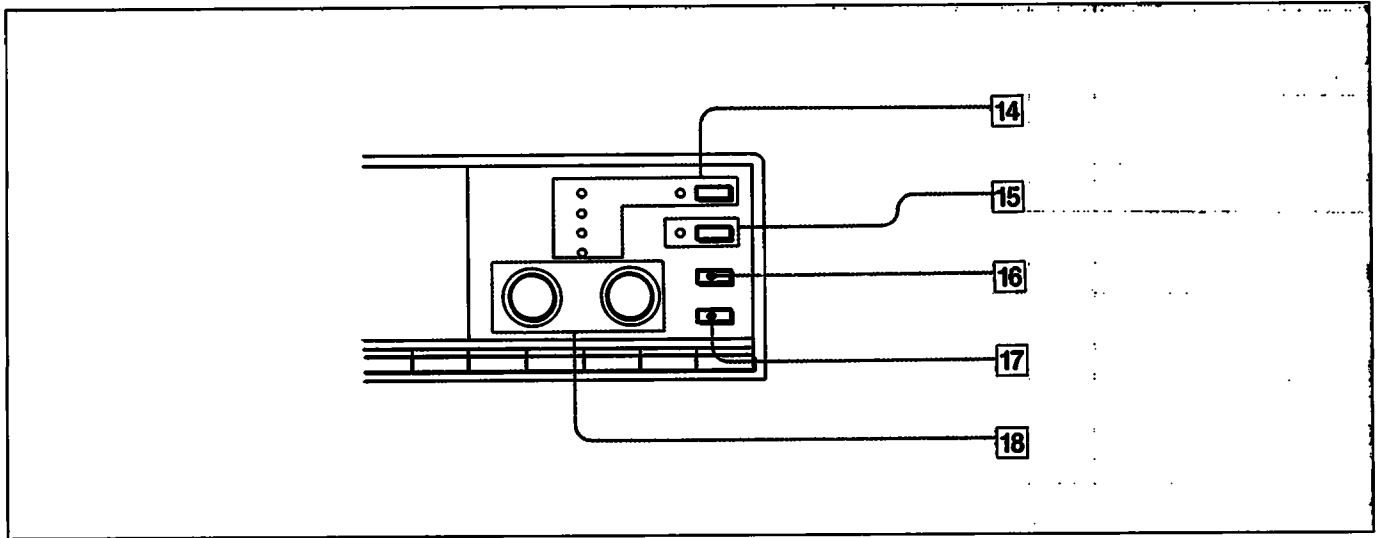

14 MAIN PARAMETER button and indicators (pagea 34, 35, 36 and 41)
 Selects the pair of main parameters to be set. The indicator lights when the main parameters can be set.

15 SUB PARAMETER button and indicator (pages 37 and 40)
 Selects the sub parameter to be set. The indicator lights when the displayed sub parameter can be set.

16 EQ BAND select button (page 41)
 Selects the desired band of the parametric equalizer.

17 EQ SLOPE select button (page 41)
 Selects the desired slope (Q) of the parametric equalizer.

18 DIGITAL PROCESSING CONTROL knobs
 Set the parameters.

Functions of Controls

—Refer to the pages indicated in parentheses for details.

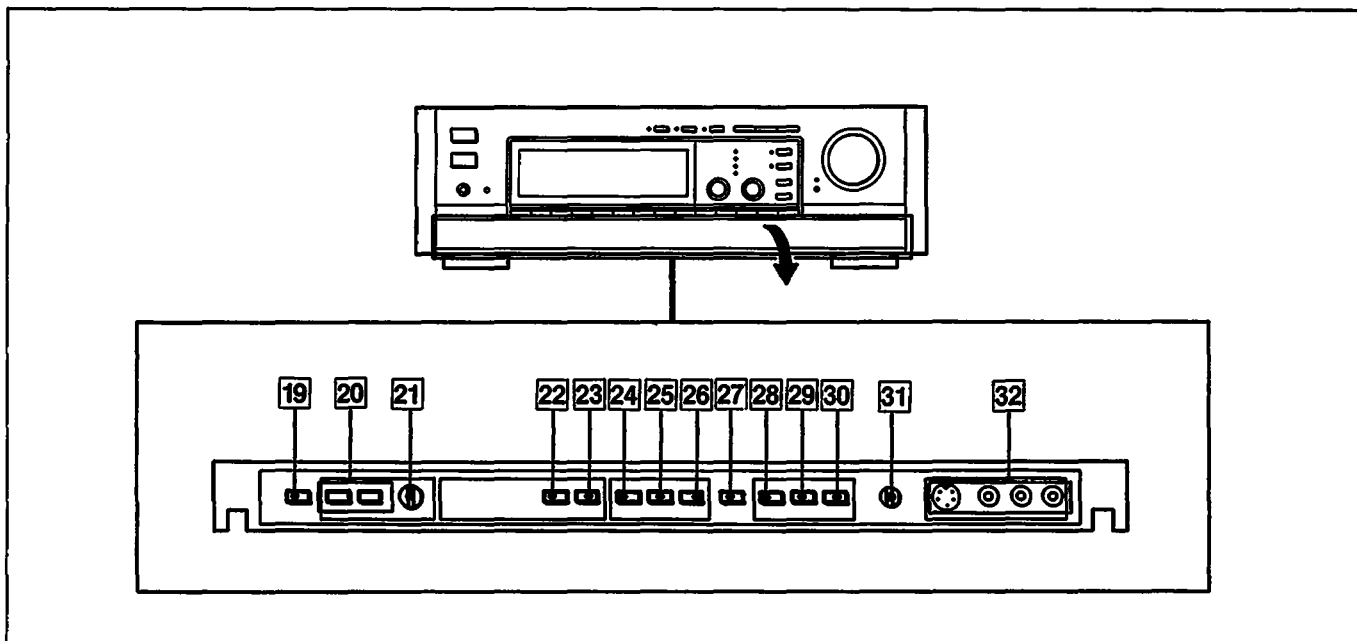

- 19 PRO LOGIC MODE button** (page 20)
Selects the operation mode of Dolby Pro Logic surround function.
- 20 DIGITAL input level buttons** (page 24)
Adjust the input level connected to the digital input jacks. Keep pressing + until just before **OVER** appears in the display.
- 21 ANALOG input level knob** (page 24)
Adjusts the input level of analog inputs. Turn the knob clockwise until just before **OVER** appears in the display.
- 22 EQ CH (equalizer channel) button** (pages 41 and 42)
Selects the channel (front, center, rear or all the channels) to be adjusted by the parametric equalizer.
- 23 FLAT button** (page 42)
Makes the channel equalizer curve being displayed be flat.
- 24 MEMORY button** (pages 28 and 43)
Stores the parameter settings and digital input assignment.
- 25 ENTER button** (pages 43 and 45)
Stores parameter settings or stores the title written.
- 26 CLEAR button** (page 28)
Clear the digital equipment assigned to an input select button.
- 27 CHARACTER button** (page 45)
Writes a title for an input select button or a sound field.
- 28 EFFECT REC (record) button** (page 31)
Outputs the digitally-processed signals to the analog recording output jacks (AUDIO OUT and REC OUT). These signals are not output to the digital recording output jack (OPTICAL 2).
When this button is set to ON, the SET button does not activate.
- 29 SET button** (page 47)
Sets the desired program source for recording while you are listening to or watching another program source.
- 30 CHECK button** (pages 46 and 47)
Displays the program source to be recorded which is selected by the SET button. Checks the former label on the sound field.
- 31 BALANCE control knob**
Adjusts the balance between the left and right front speakers. Generally, set the knob at the center position.
- 32 VIDEO 5 INPUT jacks** (page 9)
Accept S-video/video and audio input signals.

Display

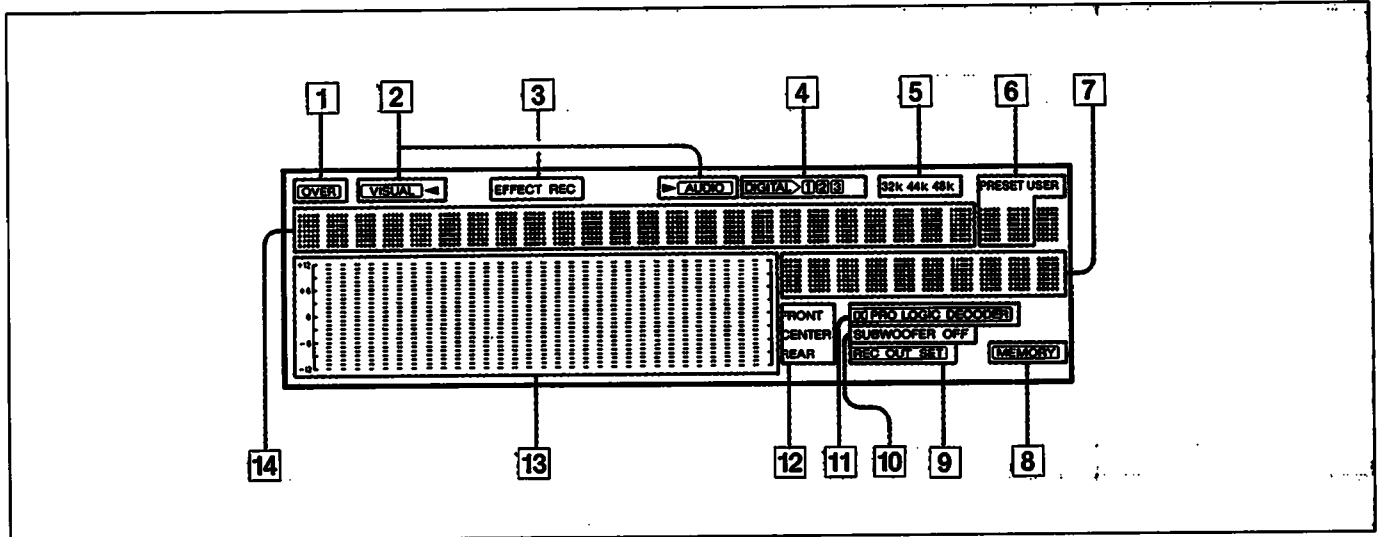

1 OVER indication

Lights when the input level is so high that the circuit clips.

2 VISUAL </> AUDIO indications

Indicate either visual input or audio input to be selected when mixing them.

3 EFFECT REC indication

Lights when the EFFECT REC button is pressed to make an effect recording.

4 DIGITAL 1 2 3 indication

Indicates the digital input selected by the DIGITAL button.

DIGITAL 1 : Input to the OPTICAL 1 IN jack in the rear panel is selected.

DIGITAL 2 : Input to the OPTICAL 2 IN jack is selected.

DIGITAL 3 : Input to the COAXIAL IN jack is selected.

5 Sampling frequency indicator

Indicates the sampling frequency of the digital signal input. (For example, in the case of a CD, 44k is indicated.)

6 PRESET/USER sound field number indication

Indicates the number of the PRESET/USER select button setting or the number of the sound field.

7 Sound field name indication

Indicates the sound field name selected.

8 MEMORY indication

Appears when you press the USER button to store the parameter settings. When designating the sound field number to be stored and pressing the ENTER button, the MEMORY indication disappears showing that the storing has been complete. (In the case of the remote commander, the MEMORY indication appears when you press the MEMORY button and disappears when you press the sound field number button.)

9 REC OUT SET indication

Appears when the SET button is pressed and disappears when the SET button is pressed again.

10 SUBWOOFER OFF indication

Lights when the subwoofer output is muted by the remote commander.

11 PRO LOGIC DECODER indication

Lights when the Pro Logic Decoder is used.

12 FRONT CENTER REAR indication

Indicates the FRONT, CENTER or REAR channel whose tone quality is to be adjusted.

13 Equalizer curve indication

Indicates the equalizer curve.

14 Character indication

Indicates a sound field name, program source, operation mode or warning concerning incorrect operation.

When the line output signals are muted, MUTING ON is indicated.

Functions of Controls —Refer to the pages indicated in parentheses for details.

Programmable Remote Commander RM-P2000

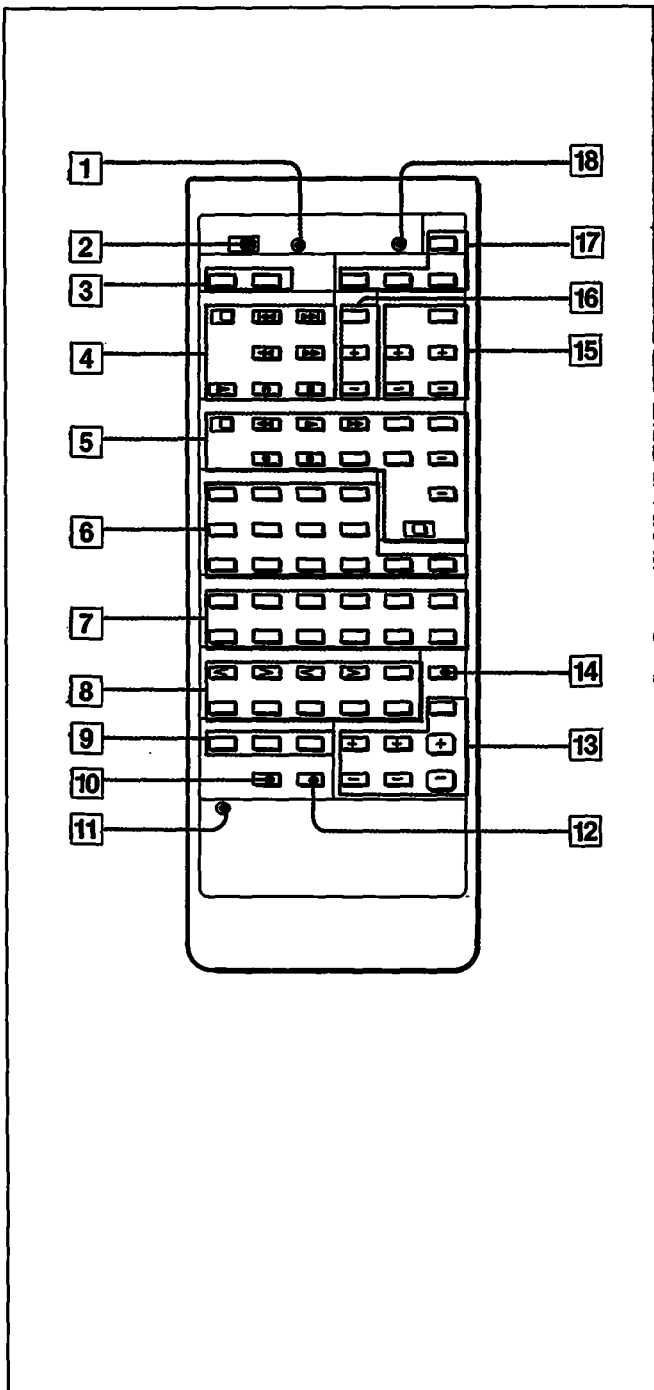

The RM-P2000 can "learn" various functions of other remote control units which use infrared rays. When the mode selector is set to SONY STD (Sony standard), you can use the buttons on the RM-P2000 to perform the functions as follows.

- 1 LEARN indicator (page 48)**
Is used to confirm operation when storing the signals of other remote control units.
- 2 Mode selector (page 48)**
SONY STD: To control Sony equipment.
USER STD: To control the equipment whose remote control functions are stored.
LEARN: To store functions of other remote control units that use infrared rays.
- 3 DISPLAY buttons**
MODE (display mode) button
Selects the display in the following order.
All indications are displayed → Name of equipment being input is displayed → Only the MASTER VOLUME indicator lights (When operating other buttons or knobs, their indications light automatically for several seconds.) → All indications are displayed.
DIMMER button
Adjusts the brightness of the display to one of three levels.
- 4 CDP/LDP control button (page 48)**
CDP/LDP selector: Selects the equipment to be controlled.

 - ▶ : Play
 - || : Pause
 - : Stop
 - ◀▶ : AMS (Automatic Music Sensor) — Locates a desired selection
 - ◀ ▶ : Search (for LD player only)
- 5 TAPE/VTR control buttons (page 48)**
TAPE/VTR selector: Selects the equipment to be controlled.

 - ▶ : Playback
 - || : Pause
 - : Stop
 - ◀ : Rewind
 - ▶▶ : Fast forward
 - : Record (Press this button together with the button to the right of this button to start recording.)

You can use the following buttons when the TAPE/VTR selector is set to VTR.

 - DUAL : Selects bilingual programs.
 - ANT TV/VTR : Selects output signal from the antenna terminal on the VCR.
 - CH +/- : Selects a higher or lower preset channel.
 - VTR selector : Selects VCR 1, 2 or 3.
- 6 Input select buttons: Work in the same way as buttons on the main unit. (page 26)**

7 Sound field buttons (page 29)

PRESET/USER: Selects either the sound fields preset at the factory or the sound fields preset by the user.

MEMORY button: Stores the parameter setting and digital input assignment.

Sound field select buttons (1-10): Select a desired sound field.

8 Parameter control buttons: Work in the same way as the buttons on the main unit.

DIGITAL PROCESSING CONTROL button

MAIN PARAMETER button

SUBPARAMETER button

EQUALIZER CH (channel) button

EQUALIZER BAND button

EQUALIZER SLOPE button

EQUALIZER FLAT button

9 Digital sound processing buttons: Work in the same way as the buttons on the main unit.

PARAMETRIC EQ (equalizer) button

DYNAMICS button

SURROUND button

10 TEST TONE button (page 22)

Turns on and off the test tone to adjust the balance among the front, center and rear speakers.

11 RESET button (page 49)

Is used when the remote commander does not work correctly.

12 SUB WOOFER button

Mutes the subwoofer outputs. **SUB WOOFER OFF** appears on the display. Press again to release.

13 Volume control buttons

MASTER VOL +/-: Adjust the level of the **LINE OUT** and **HEADPHONES** jacks.

REAR VOL +/-: Adjust the level of the rear speakers.

CENTER VOL +/-: Adjust the level of the center speakers.

MUTING: Mutes the line outputs. **MUTING ON** appears in the display. Press again to release.

14 SOURCE DIRECT button

Directly outputs the program source sound without passing through the parametric equalizer, dynamics and surround. Rear and center outputs are disconnected and signals are output from the front and subwoofer. Press the button again to release. During **EFFECT REC** mode, when you press the **SOURCE DIRECT** button, **EFFECT REC** mode will be released.

15 TV control buttons

TV/VIDEO: Selects the input to the TV.

VOL +/-: Adjust the volume.

CH +/-: Select the preset channel.

16 Tuner control buttons

BAND: Selects the frequency band.

PRESET +/-: Select the preset number.

17 Power buttons

POWER: Turns this amplifier and the equipment connected to the **SWITCHED** outlets on and off.

TV POWER: Turns the TV on and off.

VTR POWER: Turns the VCR selected by the VTR 1, 2, 3 selector switch on and off. (Works only when the **TAPE/VTR** selector is set to VTR.)

LDP POWER: Turns the LD player on and off.

18 PROGRAM CLEAR button (page 49)

Clears all the stored signals.

Getting Ready to Enjoy Surround Effect

To enjoy the surround effect to the utmost, placement of the speakers plays a very important role.

This section describes the efficient placement of the speakers and how to adjust the speaker volume.

In Dolby surround mode, adjustment of the volume of each speaker and adjustment of the delay time of the rear speakers are required.

Placement of Speakers and Selecting the Pro Logic Mode

Where you place the speakers depends on the size and acoustics of the room where the system is to be installed. The examples shown here only represent typical cases. We recommend that you experiment to find the speaker direction or location in which the most effective acoustics can be obtained.

Then select the Pro Logic mode according to your speakers. Pro Logic mode is active only when the **PRO LOGIC DECODER** indication appears; adjust it beforehand to enjoy Dolby surround mode.

How to select the Pro Logic mode

- 1 Press the **PRESET/USER** button.
PRESET appears on the display.
- 2 Select preset number 10 by pressing the **SOUNDFIELD PROGRAM** button. (In the case of the remote commander, press the button number 10.)
- 3 Press the **PRO LOGIC MODE** button to select the mode according to your speakers.
Each time you press the **PRO LOGIC MODE** button, the indication changes as follows.

→ PHANTOM → 3 CH.LOGIC → NORMAL → WIDE →

When you use five or six speakers in total

Two front speakers, two rear speakers and one or two center speakers are used. This is the most ideal speaker placement in order to enjoy Dolby Pro Logic surround sound as well as to make the most of this amplifier. When you use two center speakers, place them beside the TV.

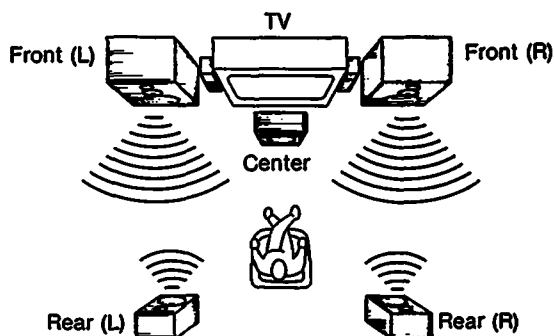

Set the **PRO LOGIC MODE** button to **NORMAL** or **WIDE** according to the size of the center speaker(s).

NORMAL: Select this mode when you use small center speaker(s). The bass sound is distributed to left and right front speakers equally as the small center speaker(s) cannot produce enough bass.

WIDE: Select this mode when you use medium-sized or large center speaker(s).

When you use four speakers

Two front speakers and two rear speakers are used.

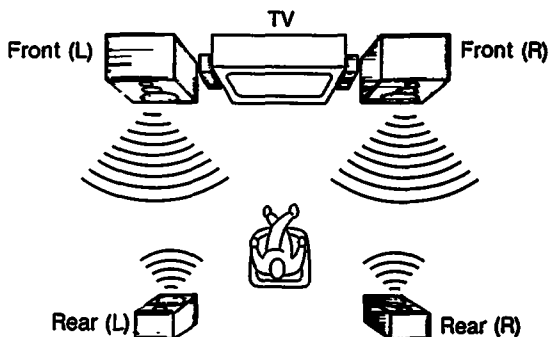

Set the **PRO LOGIC MODE** button to **PHANTOM**.

The center channel is distributed to left and right front speakers equally since a center speaker is not used.

Others

- When using only three speakers (two front speakers and one center speaker), set the PRO LOGIC MODE button to 3CH. LOGIC. We recommend you that you use rear speakers too, as this amplifier has been designed on the premise that rear speakers would be used.
- One or two subwoofer speaker(s) can be added to obtain rich bass sound. Position the subwoofer speaker(s) anywhere forward of your primary listening position. A deep bass sound is not as directional as the higher frequencies and therefore will not affect the stereo image.

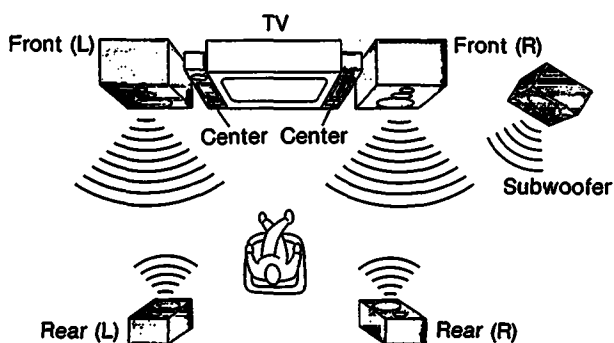

- You can use two center and two subwoofer speakers in addition to two front and two rear speakers depending on the location or on your preference.

What is Dolby Pro Logic Surround?

Dolby Pro Logic Surround is a new standard from Dolby Laboratories Licensing Corporation, that was developed by improving the sound imaging capability of conventional Dolby Surround. Thanks to Dolby Laboratories Licensing Corporation's unique directionality emphasis circuitry, sound imaging has been greatly improved, as can be seen in the figure. Dolby Surround is basically a home theater audio system. Pro Logic is playback technology that uses professional decoder technology to recreate the sound field of a two-channel Dolby Surround signal as it was intended by the creators of the movie. Therefore, no special entertainment software created especially for use with Pro Logic is required; Pro Logic works with conventional Dolby Surround movie and music software.

	Pro Logic mode	Conventional mode
Sound from FR to FL		
Sound of FL only		
Sound of rear center		
Sound from rear to front		
Sound of front center		

FL (Front Left)
 FR (Front Right)
 FC (Front Center)
 RL (Rear Left)
 RR (Rear Right)

Getting Ready to Enjoy Surround Sound Effect

Adjusting the Speaker Volume Level

To enjoy the surround sound to the maximum when you play any program source, adjustment of each speaker level is necessary. To make this adjustment easy, use the test tone in DOLBY SURROUND mode. (The PRO LOGIC MODE button should be adjusted in advance according to your speaker system.)

Once you adjust the level in DOLBY SURROUND mode, it is not necessary to make adjustments in any other mode.

Adjust the speaker volume level from your listening position using the remote commander.

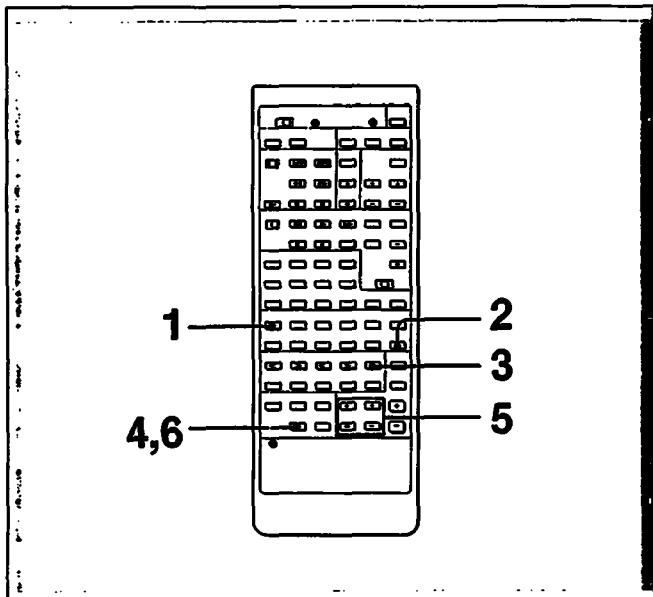

1 Press the **PRESET/USER** button. PRESET appears in the display.

2 Press the **DOLBY SURROUND** button (10) to select DOLBY SUR.

3 Press the **MAIN PARAMETER** button until C = xxdB L,R = xxdB xxdB appears. (Designated figures are displayed in the xx positions.)

4 Press the **TEST TONE** button. The test tone will be output in the order as follows.
When the center speaker is used (PRO LOGIC MODE button is set to WIDE or NORMAL): Front left → Center → Front right → Rear left and right → Front left in succession.

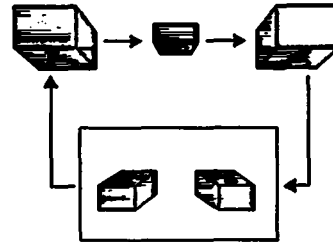

When the center speaker is not used (The PRO LOGIC MODE button is set to PHANTOM): Front left and right → Rear left and right alternately.

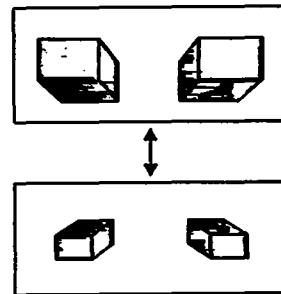

5 Adjust the level of the speakers. When you start adjusting, the test tone stops on that channel. Match the center speaker level (if used) to the front speaker level with the **CENTER VOL** buttons. Match the rear speaker level to the front speaker level with the **REAR VOL** buttons.

6 Press the **TEST TONE** button to stop the test tone. Speaker volume adjustment is now complete. If the left and right rear speakers are located at different distances from your listening position, proceed with rear speaker adjustment on the next page.

Balance adjustment between the rear speakers

- 1 Press the SUB PARAMETER button until Each Rear appears in the display.

- 2 Press the DIGITAL PROCESSING CONTROL buttons to precisely adjust the volume level of the left and right rear speakers.

Adjustment of rear left speaker

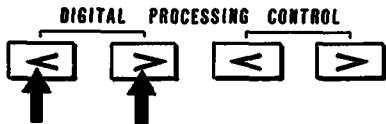

Adjustment of rear right speaker

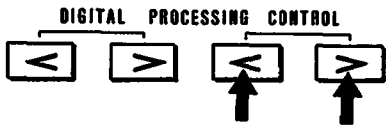

Speaker level adjustment with the buttons on the main unit

Speaker level adjustment with the remote commander at the listening position is desirable, but you can also adjust the speaker level with the buttons on the main unit.

- 1 Press the MAIN PARAMETER button until C = xxdB, L,R = xxdB xxdB appears in the display. (The designated figures appear in the xx positions.)

- 2 Adjust the center speaker level with the left DIGITAL PROCESSING CONTROL knob. Adjust the rear speaker level with the right DIGITAL PROCESSING CONTROL knob.

Balance adjustment between the rear speakers with the buttons on the main unit

- 1 Press the SUB PARAMETER button until Each Rear appears in the display.

- 2 Adjust the rear left speaker level with the left DIGITAL PROCESSING CONTROL knob and the rear right speaker level with the right knob.

Getting Ready to Enjoy Surround Effect

Adjusting the Input Level (main unit only)

Adjust the level of the signals which are input in this amplifier.

As a result of this adjustment, the S/N and distortion can be improved.

- Turn on the power of the audio/video equipment connected.
- When the **VISUAL** or **AUDIO** indication appears in the display, press the MIX button to make them disappear.

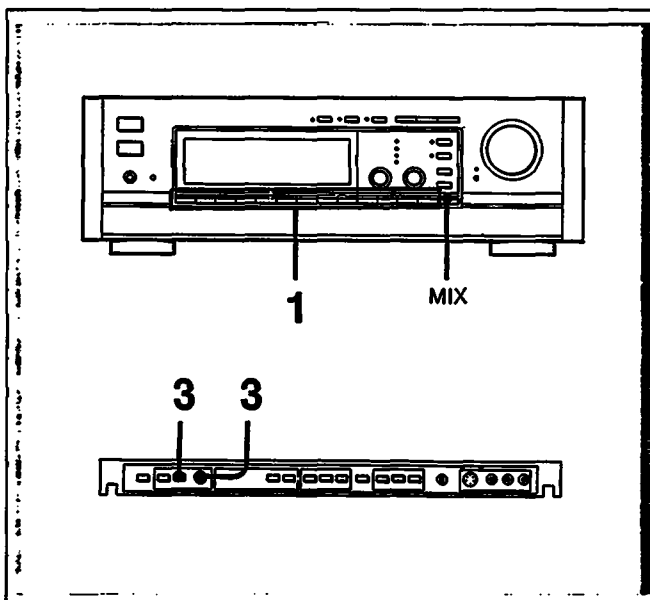

- 1 Select a program source.**
For analog input, press the appropriate button, from VIDEO1 to PHONO.
For digital input, press the DIGITAL button until OPTICAL1, OPTICAL2 or COAXIAL whichever is desired, appears in the display.

- 2 Play back the selected program source.**

- 3 Adjust the input level.**
For analog input, turn the ANALOG input level knob. For digital input, press the DIGITAL input level button (+) until just before **OVER** appears in the display.

Input level adjustment is now complete. Strictly speaking, you should adjust the input level each time you change the program source or surround mode. In general, however, set the ANALOG input level knob in the vertical position and set the DIGITAL input level at about -10dB.

Adjusting the Delay Time of the Rear Speakers (only for Dolby surround mode)

The delay time is the time difference between the surround sound from the front speakers and the surround sound from the rear speakers. The delay time is adjustable from 15.0 mS to 30.0 mS.

If the room is wide or the rear speakers are located too far from the listening position, make the delay time shorter. If the room is not wide or the rear speakers are located near the listening position, make the delay time longer. Thus, you will obtain a natural listening environment.

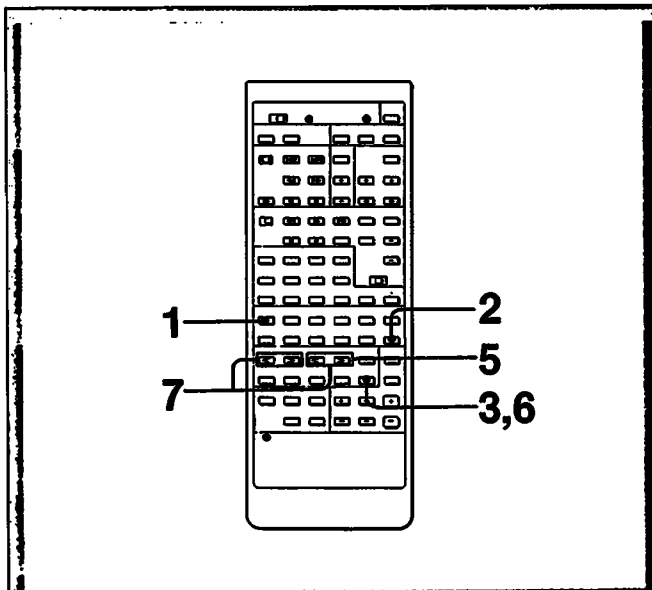

- 1** Press the **PRESET/USER** button. PRESET appears in the display.

- 2** Press **DOLBY SURROUND (10)** to select **DOLBY SUR. mode**.

- 3** Press the **SUB PARAMETER** button until **Both Del. xxxmSxxxmS** appears. (The designated figures are displayed in the xxx positions.)

- 4** Select and play back a program source. See the previous page for instructions on how to select a program source.

- 5** Adjust the delay time for both the left and right rear speakers simultaneously with the right **DIGITAL PROCESSING CONTROL** buttons.

- 6** Press the **SUB PARAMETER** button until **Each Del. xxxmSxxxmS** appears. (The designated figures appear in the xxx positions.)

- 7** Precisely adjust the left and right delay time respectively. Adjust the delay time of the rear left speaker with the left **DIGITAL PROCESSING CONTROL** buttons. Adjust the delay time of the rear right speaker with the right **DIGITAL PROCESSING CONTROL** buttons.

Listening to/Watching Program Sources

Enjoy playing back software on audio/video equipment connected to this amplifier.

Basic Operation

Perform the following steps before starting.

- Turn on the audio/video equipment.
- When the **VISUAL** or **AUDIO** indication appears in the display, press the **MIX** button to make them disappear.
- When **MUTING ON** appears in the display, press the **MUTING** button on the remote commander to make **MUTING OFF** appear.

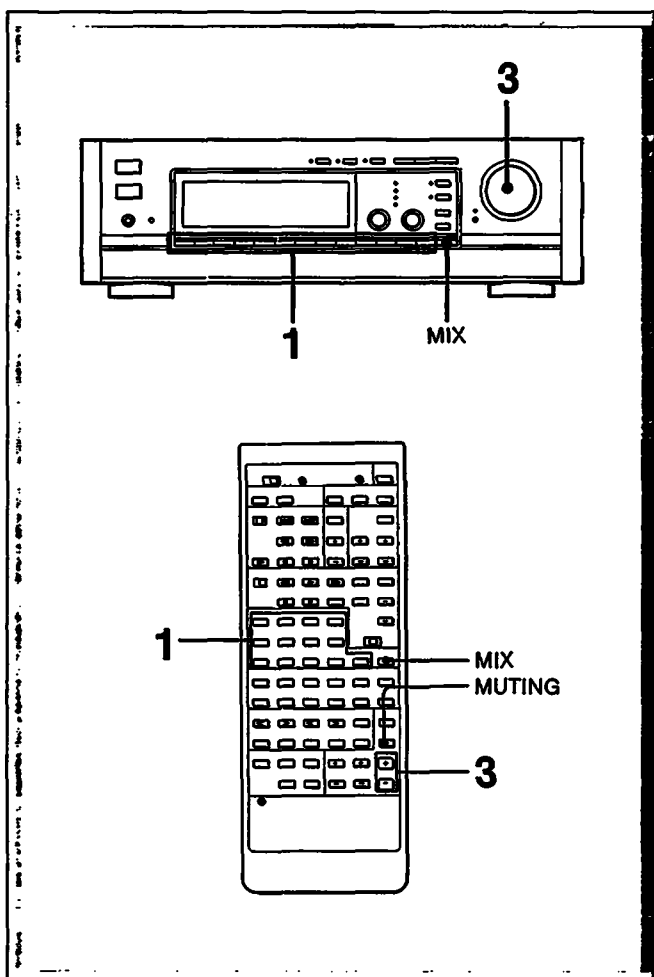

- 1** Select the program source with the input select buttons.
To play back an analog input source, press the appropriate button, from VIDEO 1 to PHONO.
To play back a digital input source, select either OPTICAL1, OPTICAL2 or COAXIAL by pressing the DIGITAL button.

- 2** Play back the program source selected.

- 3** Adjust the volume with the **MASTER VOLUME** knob. (In the case of the remote commander, press the **MASTER VOL** buttons.)

Combining the Video Image with the Sound from Another Program Source

The MIX function allows you to combine a video image with sound from another program source as background music.

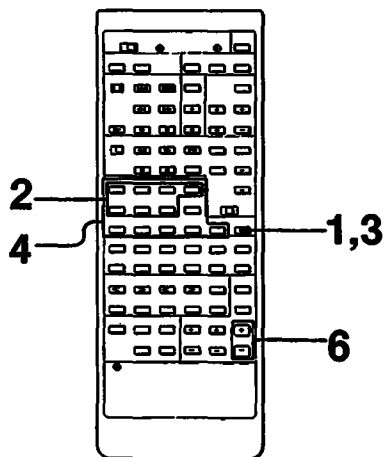
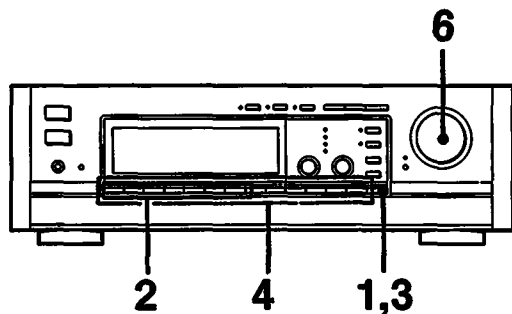

- 1** Press the MIX button.
VISUAL and AUDIO appear and the ◀ mark points to VISUAL.

- 2** Press any button from VIDEO 1 to TV to select a video program source to play back. (At this time, if you mistakenly press any button from TAPE1 to DIGITAL, "Visual only" appears, notifying you that you cannot select an audio program source.)

- 3** Press the MIX button.
The ▶ mark points to AUDIO.

- 4** Press any button from VIDEO1 to DIGITAL to select an audio program source.

- 5** Play back both video and audio program sources.
Now the video and audio are combined.

- 6** Adjust the volume.

Listening to/Watching Program Sources

Assigning Digital Audio Input to an Input Select Button

You can assign digital input to either analog input button (VIDEO 1 to PHONO). For example, when the CD player is connected to the OPTICAL1 jack, if you assign OPTICAL1 to the CD button, the CD player will be selected only by pressing the CD button. Thus there is no need to select OPTICAL1 by pressing the DIGITAL button.

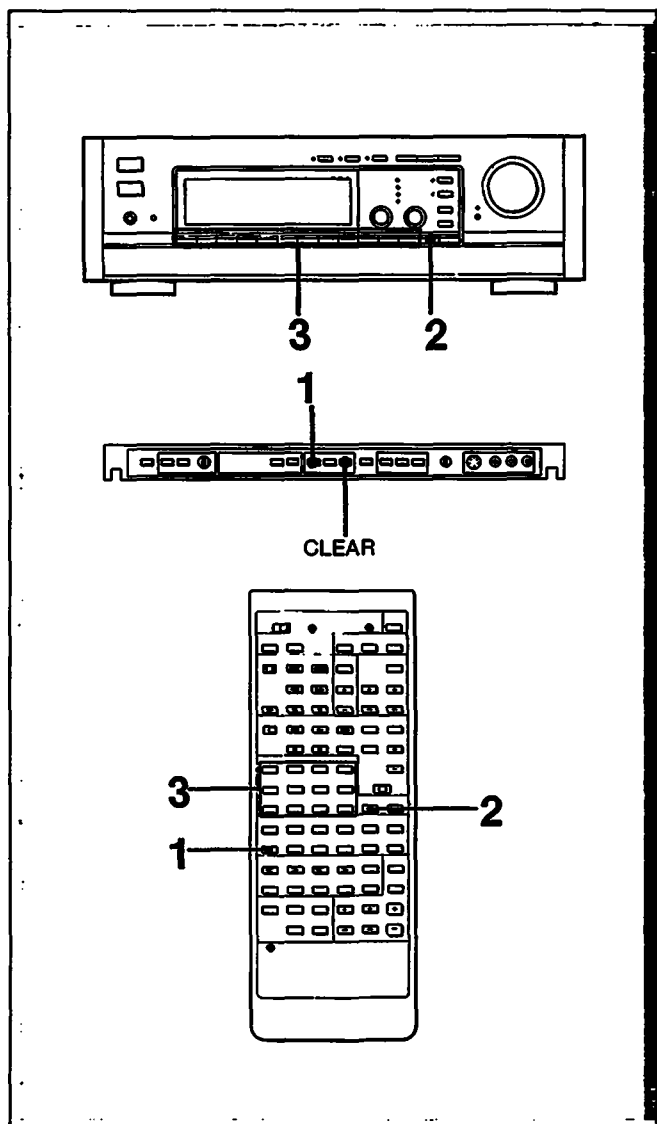

- 1 Press the **MEMORY** button. **MEMORY** appears in the display.

- 2 Press the **DIGITAL** button to select the desired digital input—**OPTICAL1**, **OPTICAL2** or **COAXIAL**.

- 3 Press the analog input select button to which you want to assign the digital input.

Analog input indication (VIDEO 1 to PHONO) still appears but either of the **DIGITAL1** to **DIGITAL3** indication also appears in the upper right. Specifying a title for the input select button will make it easy to distinguish what the button is assigned to. (Refer to page 45.)

Indications correspond as follows.

Indication in the upper right of the display	Indication on the rear panel
DIGITAL1	OPTICAL1 IN
DIGITAL2	OPTICAL2 IN
DIGITAL3	COAXIAL IN

Note
In **MIX** mode, assignment is impossible.

To cancel the assignment

- 1 Press the analog input select button.

- 2 Press the **CLEAR** button. The assignment is canceled and analog input returns to the previous condition.

Enjoying the Factory-preset Sound Fields

Ten recommended sound field programs (combinations of surround, dynamics and equalizer settings) have been preset in the factory. Since these programs are appropriate for most types of music and listening situations, you can enjoy the digital sound effects by just selecting a sound field according to the program source, etc. You can also adjust the parameters to your preference to create your individual sound fields and store them afterwards. For instruction on how to set each parameter, refer to "Creating your own sound fields" on page 34.

This section explains how to use the sound fields preset at the factory.

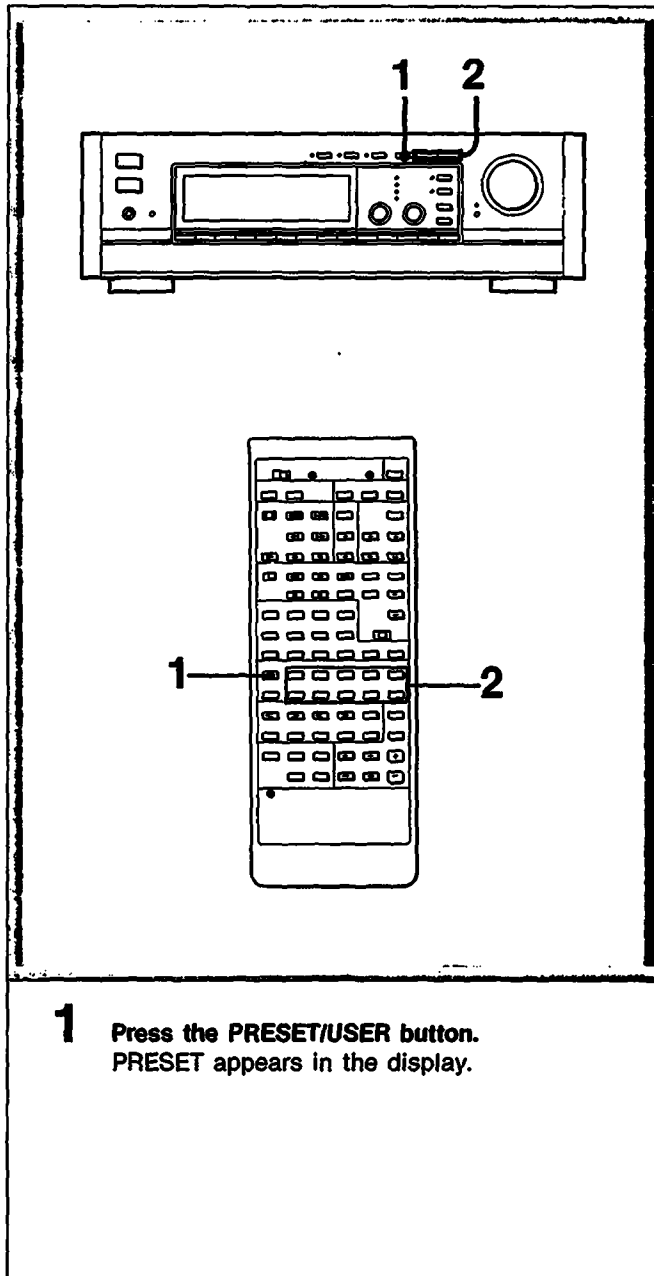

- 1** Press the **PRESET/USER** button.
PRESET appears in the display.

- 2** Press the **SOUNDFIELD PROGRAM** button to select the preset number.
(In the case of the remote commander, press the button from 1 to 10.)
See the table on the next page.

- 3** Play back a program source.

Enjoy the Factory-preset Sound Fields

Characteristics of the Sound Fields

	Sound field	Applications	Characteristics
1	HALL1	For chamber music or an instrumental solo	Reproduces the acoustics of a large rectangular concert hall with soft and natural reflection. Simulates walls made of wood, which offers soft reflection. This sound field is effective for programs such as a solo instrument or a medium-sized orchestra.
2	HALL2	For orchestral music	Reproduces the acoustics of a vineyard type concert hall with a large early reflection. Simulates walls made of wood and stone, which offer bright reflection. This sound field is effective for programs such as an orchestra or other large-scale performances.
3	OPERA	For operas or musicals	Reproduces the acoustics of an opera house, keeping the clearness of the vocal music. This sound field is effective for programs such as opera.
4	CHURCH	For church music or the pipe organ	Reproduces the acoustics of a church made of stone. This sound field is effective for programs such as baroque music, a string orchestra or a choral group.
5	JAZZ CLUB	For jazz	Reproduces the acoustics of a club with live music. The equalizer boosts high frequencies, adding sharpness to the sound. This sound field is effective for programs such as jazz.
6	DISCO	For disco music	The equalizer boosts high and low frequencies, reproducing a dynamic sound. The compressor compresses the dynamic range of the signals deeply, adding thickness to the sound. This sound field is effective for programs such as pop music with a strong beat.
7	STADIUM	For live concert in an open-air stadium	Reproduces the acoustics of an outdoor stadium with a long early reflection time. When playing back a program recorded in a studio, you may feel as if you were listening to a live concert in a stadium. This sound field is effective for programs such as pop music.
8	THEATER1	For Dolby surround movie programs or music	Adds the reflection of a large movie theater with a capacity of 1000 persons to decoded signals from the Dolby Pro Logic Decoder. Preflection is obtained. This sound field is effective for programs such as Dolby surround movie software with many spectacular scenes.
9	THEATER2	For Dolby surround movie programs or music	Adds the reflection of a small movie theater to decoded signals from the Dolby Pro Logic Decoder. Speech or narration penetrates clearly, and elegant and moderate reflection is obtained. This sound field is effective for a program source such as Dolby surround movie software with many silent and emotional scenes.
10	DOLBY SURROUND	For Dolby surround movie programs or music	Decodes programs processed with Dolby surround. Faithfully reproduces the sound field the producer intended.

Recording Audio/Video Program Sources

Play back an audio/video program source as explained so far, and record with a tape deck or VCR which is not used for playback.

Note

The audio/video signals of the analog program source are output simultaneously to all the analog output jacks (REC OUT jacks for audio signals and VIDEO OUT jacks for video signals). Therefore, simultaneous recording of audio/video using two or more tape decks or VCRs is possible.

The audio signals of a digital program source are output to digital output jack (OPTICAL2) and to analog output jacks (REC OUT and AUDIO OUT). Therefore, a digital program source can be recorded on both digital and analog decks.

The audio signals of an analog program source are not output to the digital output jacks, so they cannot be recorded on digital decks.

Recording Program Sources with Digital Sound Effects

“Sound effect” means that the original sound is processed in digital circuit. Refer to page 32. To record the signals which have been digitally-processed, press the EFFECT REC button. EFFECT REC appears in the display. Digitally-processed sounds from the front speakers now being heard are output to all the analog audio output jacks (REC OUT and AUDIO OUT) but are not output to the digital audio output jack (DIGITAL REC OUT).

When the EFFECT REC button is not pressed, an effect recording is not made even though you are listening to the digitally-processed sounds.

Notes

- When the **REC OUT SET** indication appears in the display, you cannot make effect recording. (If you press EFFECT REC button, indication of “Can not use” appears.) **REC OUT SET** indicates that signals other than those that you are listening to are output to the analog output jacks.
- When the indicator of the SOURCE DIRECT button is lit, the EFFECT REC button does not function. (“Can not use” appears.)

For timer-recording

When making a recording activated by the timer, turn on the power of this amplifier in advance.

What is DSP?

DSP (Digital Signal Processing) means that not only the digital signals but analog signals from a cassette deck or FM tuner, etc. are also changed into digital signals once and processed digitally in various ways. Afterwards, they are restored to analog signals and output.

For this amplifier, digital signal processing is possible in the following three areas. In any of these cases, press the respective button and adjust the parameters. The adjustable parameters differ according to the sound field. See page 33.

Parametric equalizer—PARAMETRIC EQ

Controls the specific frequencies or output level to raise the bass sound or lower the treble sound.

Dynamics—DYNAMICS

Compresses or expands the dynamic range of the program source. The compressor increases the low level sound and as a result, it compresses the dynamic range, making passages played pianissimo audible, for example.

Surround (Reverberation)—SURROUND

The sound heard in a place such as a concert hall or a movie theater consists of direct sound, early reflected sound (early reflections) and a reverberative sound (reverberation). This amplifier reproduces the early reflections and the reverberation using its digital signal processing circuit and allows you to produce a variety of sound fields in your own room.

Types of the sound

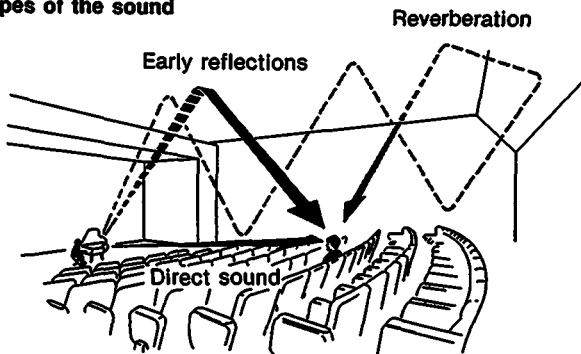

Changes in the sound

Changes in each sound in response to the level and time can be illustrated as below.

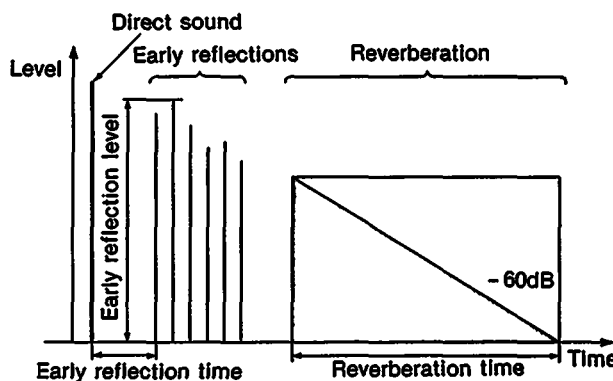

Knowing What Parameters Are Adjustable— Demonstration mode (main unit only)

While pressing the DIMMER button, press the VIDEO1 button. Each function of the parameters are indicated in succession in the display. To leave the demonstration mode, press any button.

Table of Adjustable Parameters

• marks show the adjustable parameters.

Parameter Sound Field	PARA-METRIC EQ	DYNA-MICS	SURROUND										
	MAIN	SUB	MAIN PARAMETER				SUB PARAMETER						
	Para-metric EQ	Dyna-mics	Room Size	Wall	Seat Position	Center Level Rear Level	Effect Level	Early Reflection Time	Early Reflection Level	Reverb Time	PRO LOGIC DECODER	Sepa-ration Control	Each Rear Level
HALL1	•	•	•	•	•	•	•	•	•	•	•	•	•
HALL2	•	•	•	•	•	•	•	•	•	•	•	•	•
OPERA	•	•	•	•	•	•	•	•	•	•	•	•	•
CHURCH	•	•	•	•	•	•	•	•	•	•	•	•	•
JAZZ CLUB	•	•	•	•	•	•	•	•	/	/	•	•	•
DISCO	•	•	•	•	•	•	•	•	/	/	•	•	•
STADIUM	•	•	•	•	•	•	•	•	•	•	•	•	•
THEATER1	•	•	•	•	•	•	•	•	/	/	•	•	•
THEATER2	•	•	•	•	•	•	•	•	/	/	•	•	•
DOLBY SURROUND	•	•	/	/	/	•	/	/	/	/	/	•	•

The items "Both Delay Time" and "Each Delay Time", which are not shown in this table, are adjusted only in the DOLBY SUR. mode. Center Level (level of the center speakers) can be adjusted in all the sound fields, but when PRO LOGIC DECODER does not appear in the display or when the PRO LOGIC MODE button is set to PHANTOM, the center level is not output. When the PRO LOGIC MODE button is set to 3CH. LOGIC, the rear is not output.

Creating Your Own Sound Fields (except for the DOLBY SUR. mode)

When you listen to one of the ten sound fields preset in this amplifier, sometimes you may feel that you want to add the feeling of a slightly wider room or to suppress the reverberative sound, etc. In such an instance, you can adjust the parameters (elements which compose the sound) to create your private sound fields. You can also store them in the memory (up to ten modes) and recall them afterwards.

First, select a sound field preset which is the most similar to your preferences, and begin to adjust. Even though you adjust the parameters in the sound fields preset, the original (fixed) values will not be erased.

Simulating the Room Size

The sound emitted from a sound source is reflected many times between the left and right walls, ceiling, and floor. Thus, the time until the early reflections reach our ears differs according to the size of the room. The **ROOM SIZE** parameter controls the spacing of early reflections to simulate the room size. You can adjust this parameter from 0.5 to 2.0. The higher the value, the larger the size of the simulated room. In every sound field preset, room size is designated as 1.0.

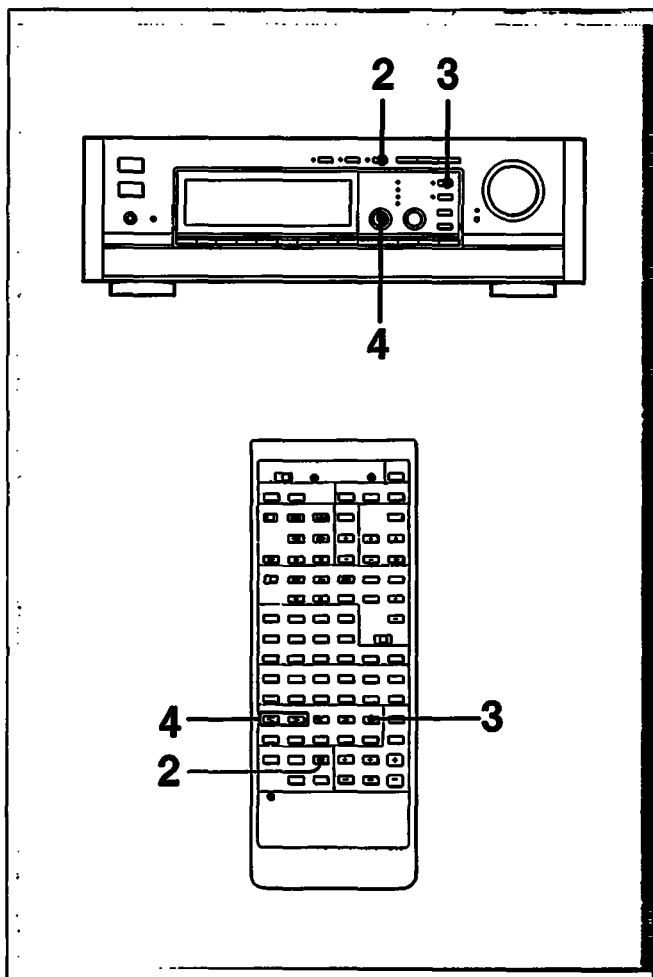

1 Play back a program source.

2 Set the **SURROUND** button to **ON**.

3 Press the **MAIN PARAMETER** button to select **ROOM SIZE-WALL**.

4 Adjust the **ROOM SIZE** parameter.

Room = 0.5 (a small room)

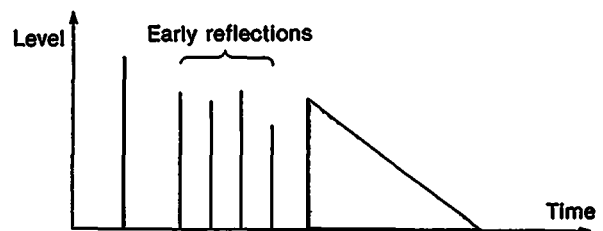

Room = 2.0 (a large room)

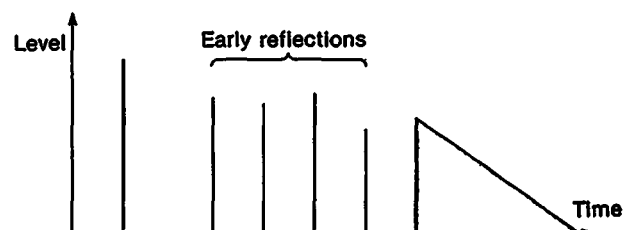

Simulating the Wall Material

When a sound is reflected by a wall made of soft material such as wood or a wall covered with a curtain, the high frequency components are reduced. A hard wall is highly reflective and does not significantly affect the frequency response of the reflected sound. The WALL parameter controls the level of high frequencies to simulate the wall material. The standard wall made of wood is designated as 1, and you can adjust this parameter from 0.5 to 2.0. The higher the value, the harder the simulated wall.

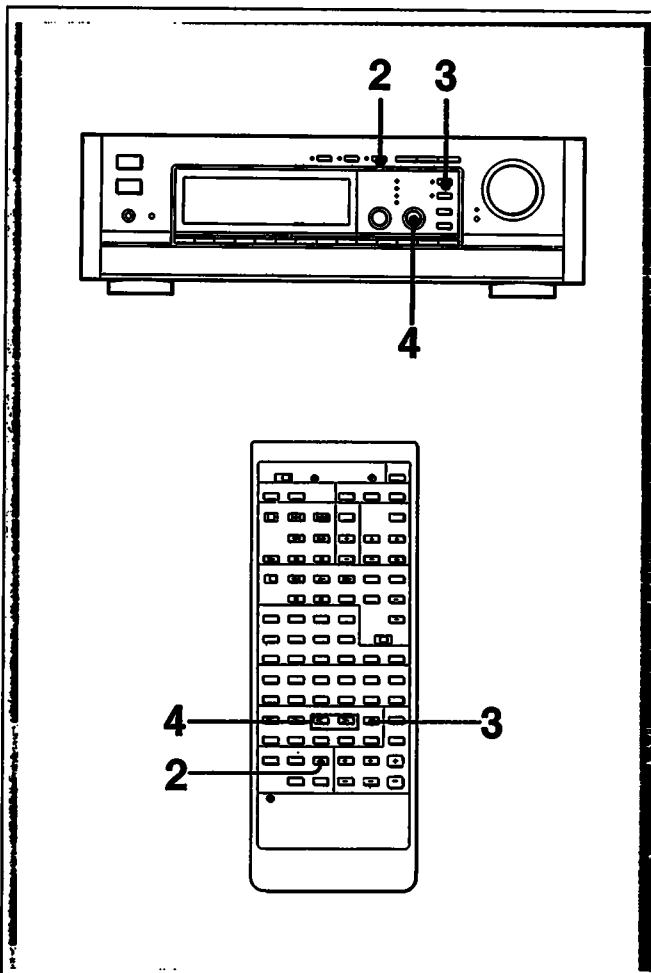

1 Play back a program source.

2 Set the SURROUND button to ON.

3 Press the MAIN PARAMETER button to select ROOM SIZE-WALL.

4 Adjust the WALL parameter.

Wall = 0.5 (wall is soft)

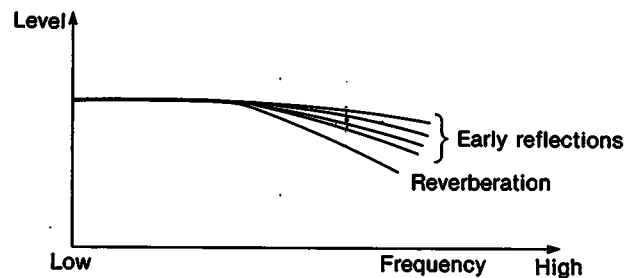

Wall = 2.0 (wall is hard)

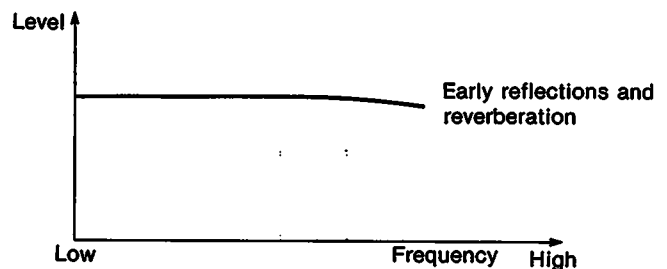

Creating Your Own Sound Fields (except for the DOLBY SUR. mode)

Simulating the Seat Position

When you sit in the front of a room, you will hear more direct sound from the front, and the component of reflected sounds from the front grows as you move to the rear. Similarly, the component of reflected sound changes when you move from left to right, and vice versa. The SEAT POSITION parameters control the balance of the direct and reflected sound and other components of sound to simulate your listening position.

The center position is designated as 0, both in the rear-front and left-right parameters, and you can adjust the position in 50 increments in each direction. The higher the number, the more your position will be offset from the center of the room.

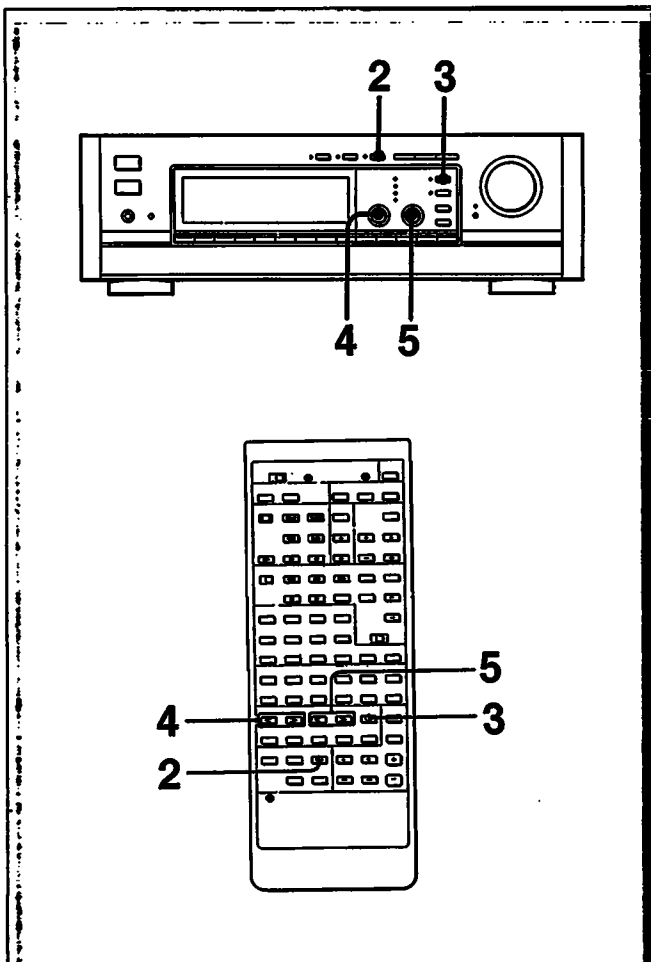

1 Play back a program source.

2 Set the SURROUND button to ON.

3 Press the MAIN PARAMETER button to select SEAT POSITION.

4 Adjust the rear-front parameter.
R-F = xxx appears. (In the xxx digits, set the seat number from R50 to F50.)

5 Adjust the left-right parameter.
L-R = xxx appears. (In the xxx digits, set the seat number from L50 to R50.)

HALL 2 and STADIUM sound fields

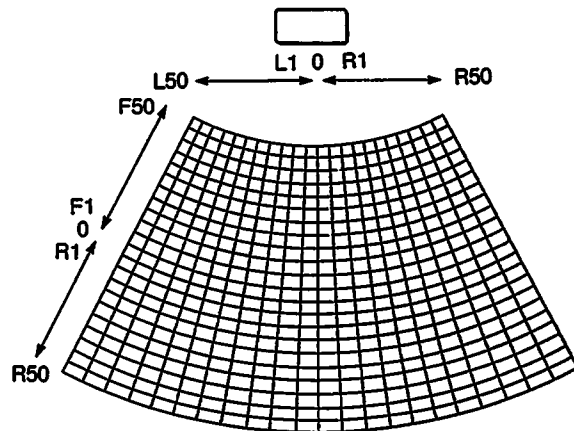

Other sound fields

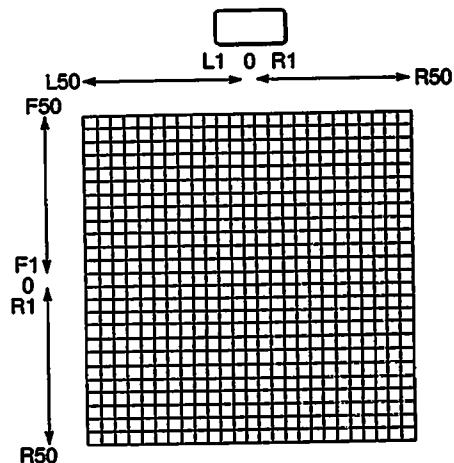

Adjusting the Sub Parameters

Sub parameters finely adjust the time or level of the reflections and reverberation. For any parameter, adjustment procedures are the same as follows.

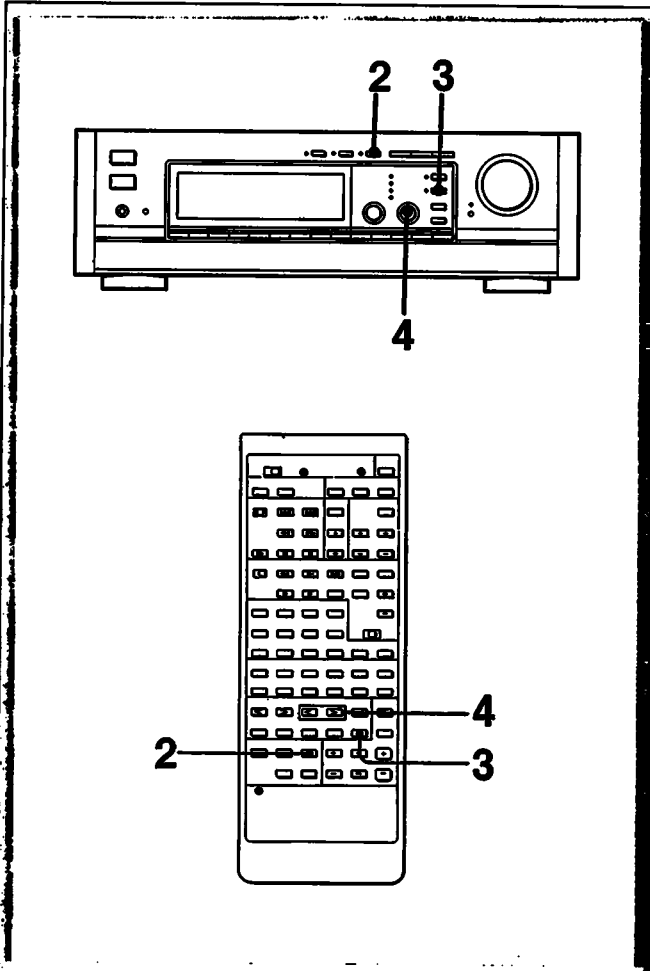

1 Play back a program source.

2 Set the SURROUND button to ON.

3 Press the SUB PARAMETER button to select the parameter to be adjusted. Name of the parameter such as E.Ref. Time, Reverb Time, etc. appears in the display.

4 Adjust the parameter.

Note

Noise may be heard while you adjust the parameter.

Early Reflection Time

This parameter controls the time required for the early reflections to reach the listening position. The Early Reflection Time is calculated automatically and varies according to the room size. The upper limit of the adjustable range differs according to the room size. When the room size is simulated as 2.0, you can adjust the Early Reflection Time up to 500mS. When the room size is simulated as 0.5, the upper limit of adjustment is 124mS.

E.Ref.Time = 2mS (adjacent to sound source)

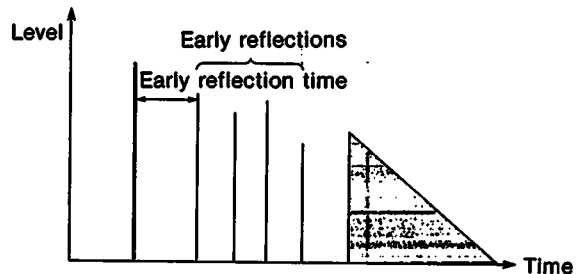

E.Ref.Time = 500mS (far from sound source)

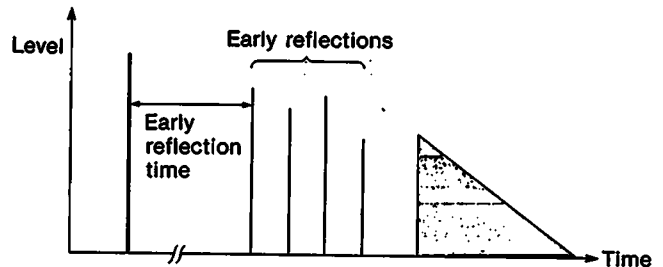

Creating Your Own Sound Fields (except for the DOLBY SUR. mode)

Early Reflection Level

The parameter controls the acoustic liveness of the room. The adjustable range is from 0 to 100%. As the percentage gets larger, the room becomes more "live"; as the percentage gets smaller, the room becomes more "dead".

E.Ref. Level = 0%
(There are no early reflections)

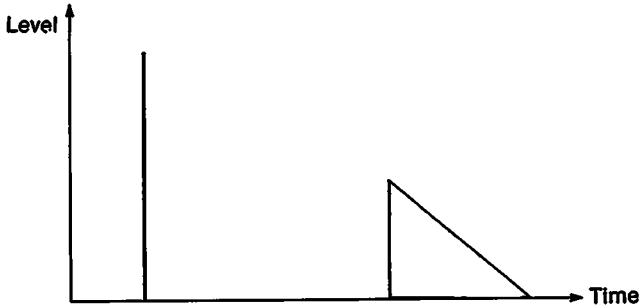

Reverb Time

This parameter controls the length of the reverberation—the time required for reverberative sound to decrease to -60dB. The adjustable range is from 0.3 sec. to 5.0 sec. The greater the value, the longer the reverberation.

Reverb Time = 0.3S
(Reverberation is shorter)

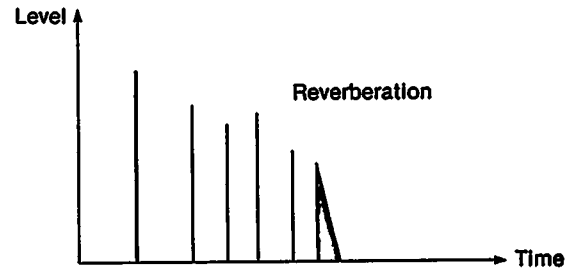

E.Ref. Level = 100%
(Maximum level of the early reflections)

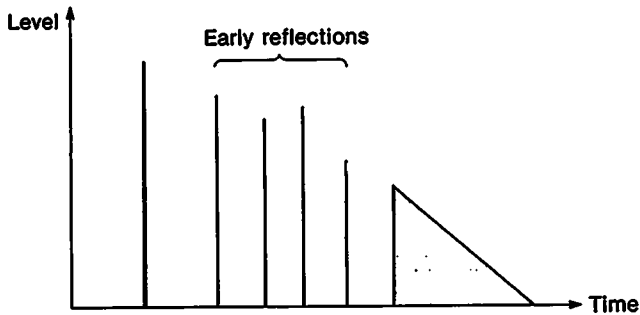

Reverb Time = 5.0S
(Reverberation is longer)

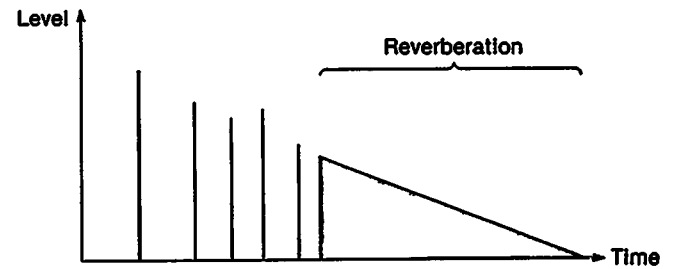

Effect Level

This parameter controls the level of early reflections and reverberation. The adjustable range is from 0 to 100%. As the percentage gets larger, the room becomes more "live"; as the percentage gets smaller, the room becomes more "dead".

Effect Level = 0%
(There are no early reflections nor reverberation)

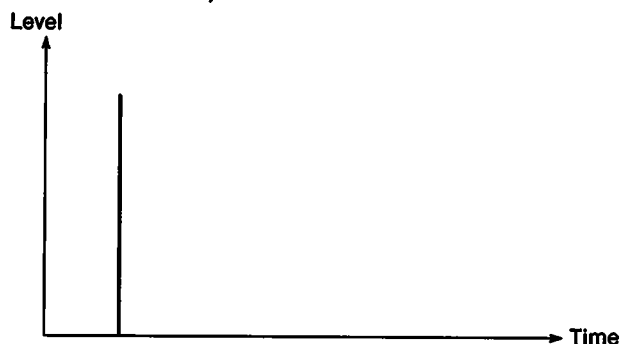

Effect Level = 100%
(Both early reflections and reverberation are at a maximum.)

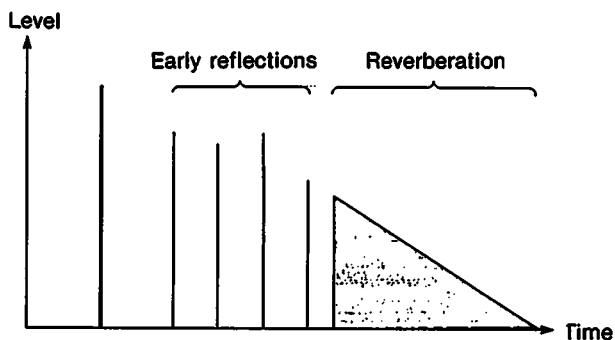

PRO LOGIC DECODER

This allows you to combine Pro Logic with the current sound field. For example, by turning PRO LOGIC DECODER on while using the JAZZ CLUB sound field, you can listen to jazz music recorded with Dolby Surround and also benefit from the superior positioning, sensation of motion, and separation provided by Pro Logic.

Separation Control—Effective only when PRO LOGIC DECODER is lit.

This allows you to control the sensation of motion and separation by varying the internal parameters of the Pro Logic Decoder. As the Pro Logic processing in this amplifier is digital instead of analog, separation and the sensation of motion have been greatly improved. Adjust this control in accordance with the size of the listening room and the positioning of the speakers.

This control can be adjusted incrementally from 0 to 10. If the separation is excessive, or if you want to recreate the feeling of conventional analog processing, set the Separation Control at or near "0". The maximum setting for the Separation Control is "10".

Adjusting the Digital Dynamics Controller

This amplifier allows you to select either of two digital dynamics controls, compressor or expander. The compressor compresses the dynamic range of the output signal to increase the average output level for obtaining dynamic sound at small output levels. On the other hand, the expander limits the dynamic range of the input signal to eliminate undesired noise between the pieces of music, etc. You can set the compressor or expander effect in nine increments.

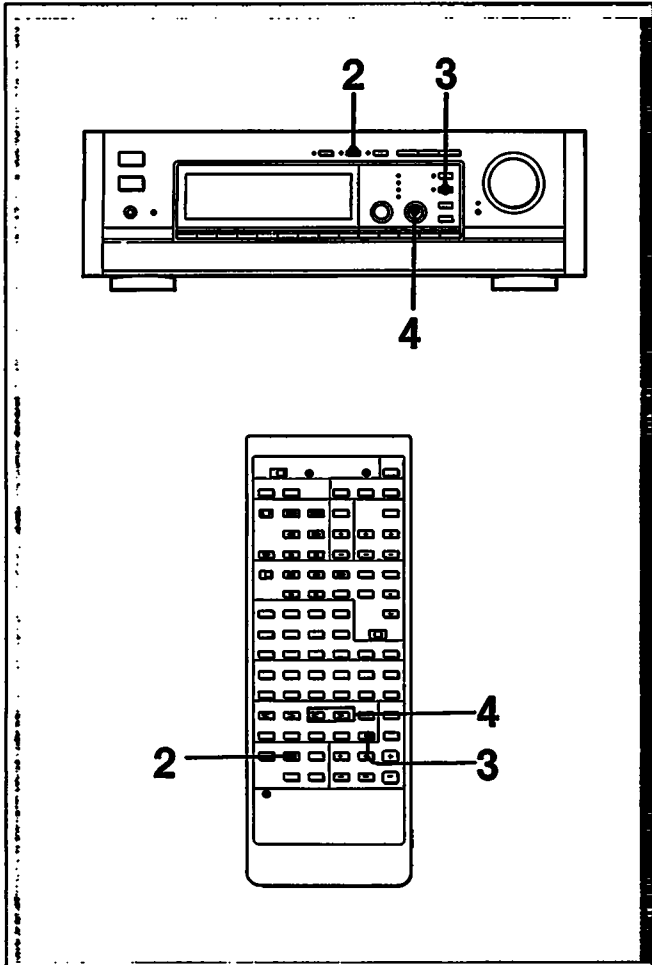

1 Play back a program source.

2 Set the **DYNAMICS** button to **ON**.

3 Press the **SUB PARAMETER** button. Dynamics appears in the display.

4 Adjust the **CMP** (compressor) or **EXP** (expander) with the right **DIGITAL PROCESSING CONTROL** knob (or buttons). The greater the value, the greater the effect.

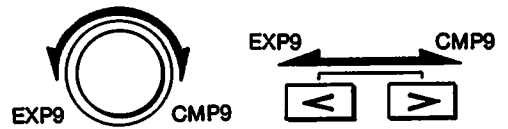

Input/output characteristics of compressor

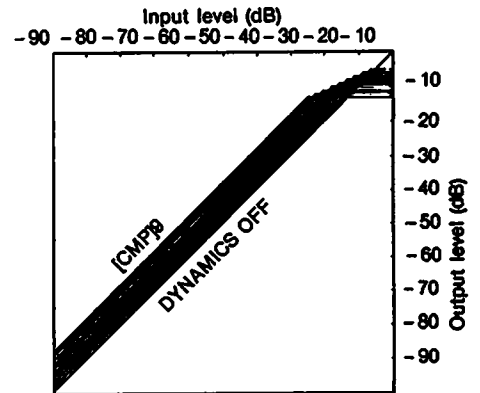

Input/output characteristics of expander

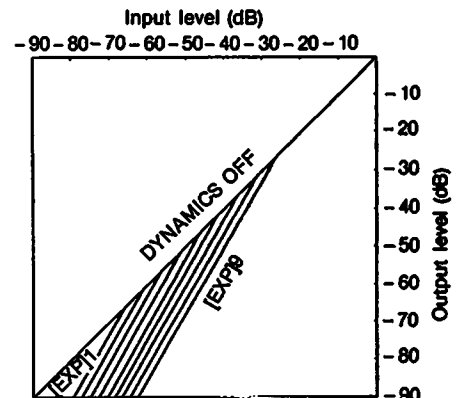

Adjusting the Digital Parametric Equalizer

The parametric equalizer is a tone control which adjusts center frequency, level and slope for each channel.

As the three characteristics in total are displayed in the display as an equalizer curve, you can accurately adjust the sound quality by referring to the curve.

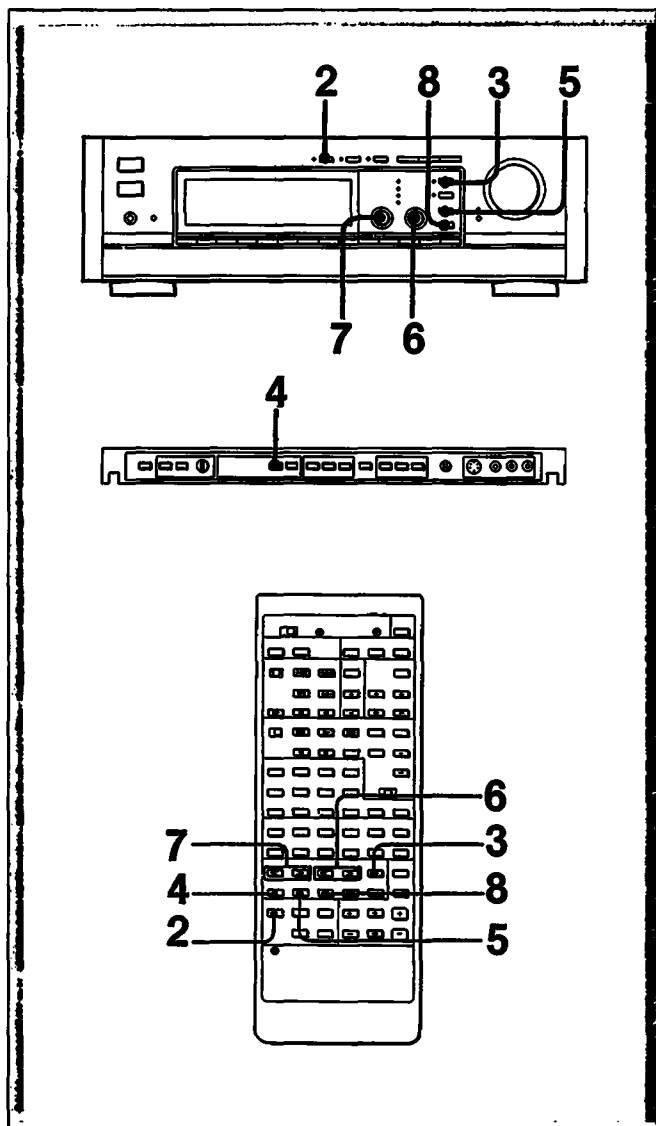

1 Play back a program source.

2 Set the PARAMETRIC EQ button to ON.

3 Press the MAIN PARAMETER button to select EQ LEVEL—EQ FREQUENCY.

4 Press the EQ CH button to select the desired channel: F (front), C (center), R (rear) or All (all channels).

5 Press the EQ BAND button to select the desired band: 1, 2 or 3.

6 Adjust the selected center frequency with the right DIGITAL PROCESSING CONTROL knob (buttons).

7 Adjust the level with the left DIGITAL PROCESSING CONTROL knob (buttons).

8 Press the EQ SLOPE button to adjust the slope (Q).
Keep pressing the button and the slope changes automatically.

9 Repeat steps 5 to 8 for other frequency bands.

10 Repeat steps 4 to 9 for other channels.

Adjusting the Digital Parametric Equalizer

Characteristics of slope

EQ level ± 12 dB
EQ center frequency 1kHz

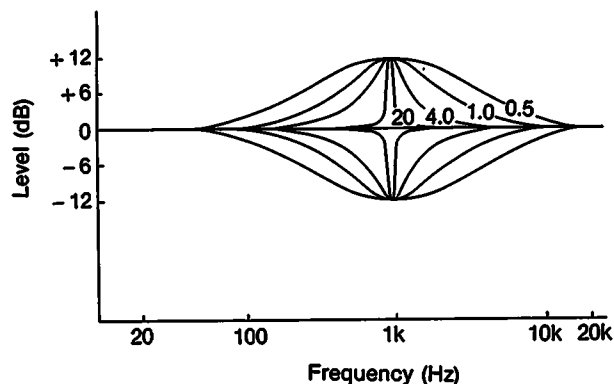

Note

When All appears in the left upper portion of the display by pressing the EQ CH button, all three indications (FRONT, CENTER and REAR) appear in the right lower portion of the display. At this time, the front equalizer curve appears in the display. When returning to FRONT by pressing the EQ CH button, the equalizer curve of All is recalled in the display.

When **OVER** appears in the display

This shows that the input level is so high that the circuit clips.

When listening to a program source connected to the analog input jacks, turn down the ANALOG input knob until the indication disappears. When listening to a program source connected to the digital input jacks, press the DIGITAL input button (-) until the indication disappears.

To create a new equalization curve from the flat condition

Press the EQ CH button (with the remote commander, press the EQUALIZER CH button) to select the desired channel. Then press the FLAT button.

The designated channel becomes flat. Create a new equalization curve.

Selecting the same center frequency for two or more frequency bands

You can add the setting levels for each band together. As a result, if the same center frequency is set for all bands, the total of the levels for each band becomes the actual level for that center frequency; therefore, the level can be adjusted over a range from -36dB to +36dB. By setting the slope (Q) to maximum, it is possible to reduce (notching) or raise (peaking) a signal at a specific frequency only. Any portion of the equalizer curve that exceeds ± 12 dB will not be shown in the display, however.

Storing Your Private Setting

You can store up to ten sound fields you create by adjusting the parametric equalizer, dynamics and surround.

Storing Your Private Setting

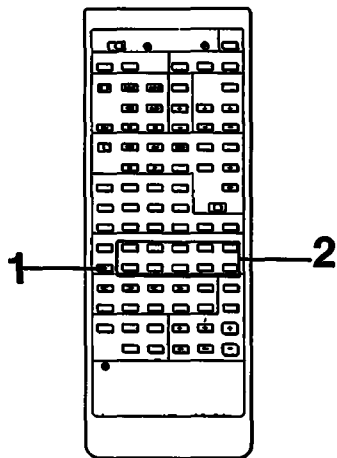
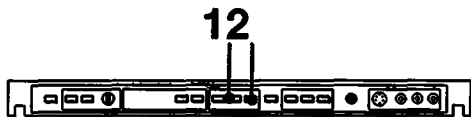
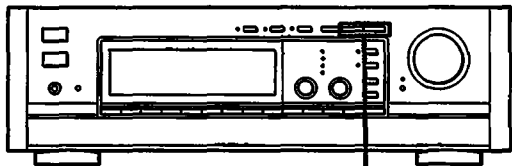

1 Press the **MEMORY** button when you have created your favorite sound.

The **MEMORY** indication appears in the display and the number flashes.

2 Press the **SOUNDFIELD PROGRAM** button (in the case of the remote commander, press any button from 1 to 10) to select the program number in which you want to store your sound field.

When storing the sound field by using the main unit, press the **ENTER** button. (In the case of the remote commander, this is not necessary.) The **MEMORY** disappears and setting is stored.

Note

If you take more than ten seconds between steps, the unit returns to the condition before step 1. In this case, proceed again with step 1.

Storing Your Private Setting

Calling up the Sound Field Setting

- 1** Press the **PRESET/USER** button. **USER** appears in the display.
- 2** Press the **SOUNDFIELD PROGRAM** button to select the desired number.

On the PRESET/USER button and sound field setting

There are ten sound fields in each position PRESET and USER of the PRESET/USER button. Ten sound fields in the PRESET position are already preset at the factory; you can store your ten sound fields in the USER position. As your sound fields are automatically stored in the USER position, it is not necessary to set the PRESET/USER button. At the time of shipping, the same sound fields are stored in both PRESET and USER positions. To change the title of a sound field in the USER position, refer to the next page.

When you store a new sound field in the preset number already stored

The previous sound field will be erased and the new one will be stored.

To return to the initial settings

- 1** Press the **POWER** switch to turn the amplifier off.
- 2** While holding down the **CLEAR** button, press the **POWER** switch to turn the amplifier on again. Sound fields stored, assignment of digital inputs to analog input buttons (see page 28), and titles assigned to input select buttons (see page 45) will be initialized.

Even if the AC power cord is disconnected

The stored data is maintained for approximately two weeks.

Assigning Titles

You can put a title of up to nine characters on an input select button or a stored sound field. For example, on the input select button VIDEO1 or VIDEO2, you can put a title such as "8mm" or "VHS" which clearly describes the connected equipment, or else you can put an appropriate title for a concert hall or a kind of music. These titles will be indicated in the display when selecting the input select button or the sound field, clearly describing the contents of an input select button or a sound field.

Usable characters and symbols

A	B	C	D	E	F	G	H	I	J	K	L	M	N	O	P
Q	R	S	T	U	V	W	X	Y	Z	[\]		_	↓
a	b	c	d	e	f	g	h	i	j	k	l	m	n	o	p
q	r	s	t	u	v	w	x	y	z	!	→	#	←	%	
&	'	()	*	+	,	-	.	/	0	1	2	3	4	5
6	7	8	9	:	;	<	=	>	?	†					

Note

The title of the analog input select button (VIDEO 1 to PHONO) has priority over the title of a digital input select button (DIGITAL) when the digital input select button is assigned to the analog input select button.

Assigning a Title to an Input Select Button (possible only on the main unit)

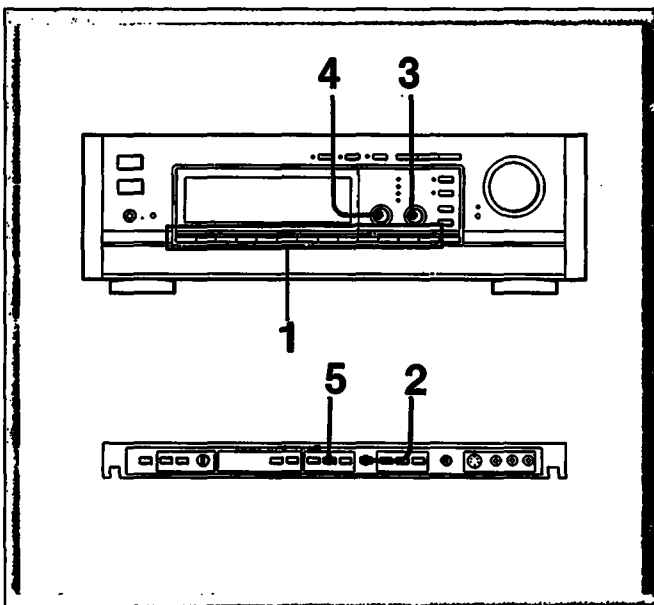

- 1** Press the input select button (VIDEO 1 to DIGITAL) to which you want to assign a title.
- 2** Press the CHARACTER button.
- 3** Enter the first character in the flashing space with the right DIGITAL PROCESSING CONTROL knob.
- 4** Move the flashing space to the right with the left DIGITAL PROCESSING CONTROL knob. Repeat steps 3 and 4 to create a title of up to nine characters.
- 5** Press the ENTER button.

Assigning Titles

Assigning a Title to a Sound Field

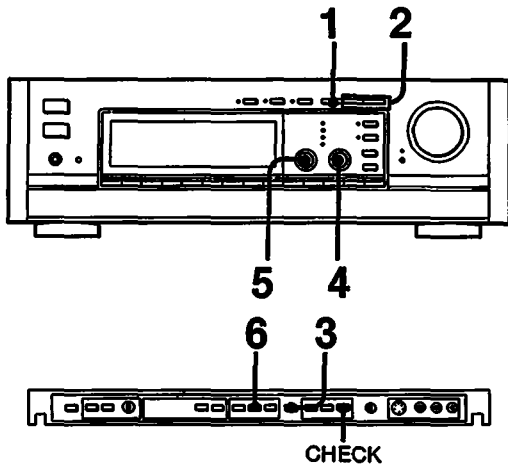

1 Press the **PRESET/USER** button.
The **USER** indication appears in the display.

2 Press the **SOUNDFIELD PROGRAM** button until **Userxxxx** appears in the display. (A title already input appears in the **xxxx** positions.)

3 When **Userxxxx** appears, press **CHARACTER** button.

4 Enter the first character in the flashing space with the right **DIGITAL PROCESSING CONTROL**.

5 Move the flashing space to the right with the left **DIGITAL PROCESSING CONTROL**. Repeat steps 4 and 5 to put a title of up to nine characters.

6 Press the **ENTER** button.

When assigning a new title on a title already entered. The previous title will be erased and the new one will be entered. To erase unnecessary characters of the previous title, enter a blank space (located between "z" and "!").

To check the previous title
Press the **CHECK** button. While the **CHECK** button is pressed, the previous title appears in the display.

Recording Program Sources while Listening to/Watching Another

This amplifier incorporates separate circuits for line output and recording output, so you can record a program source other than the program source you are now listening to or watching.

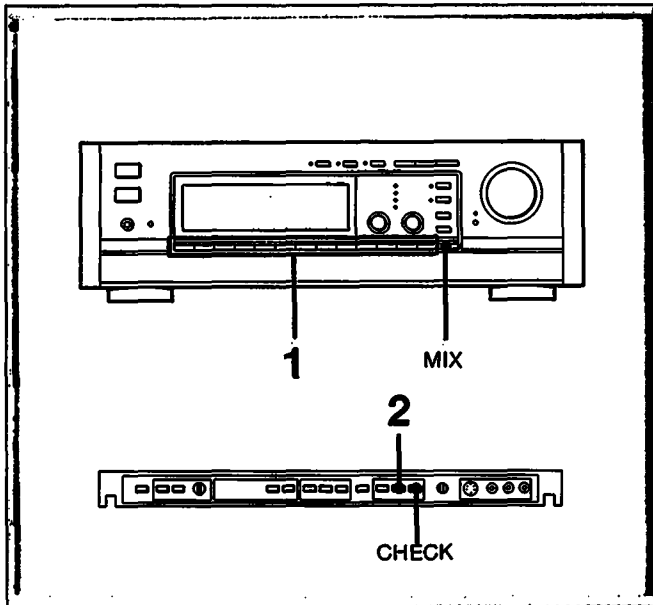

1 Press an input select button to select the program source to be recorded. When you want to mix different audio and video sources, first press the MIX button and select the audio and video sources (see page 27).

2 Press the SET button. **REC OUT SET** appears in the display, which shows that the indicated audio and video sources are going to be recorded.*

3 Play back the program sources which are going to be recorded.

4 Start recording with a tape deck or a VCR. After completing these steps, you can select another program source to play back, which will not affect the recording.

Checking the program source to be recorded

After the step 2, press the CHECK button. While you press the CHECK button, the program source selected for recording is indicated in the display.

When you are making a digitally-processed recording
You cannot record another program source.

To change recording to the program source being listened to or watched

Press the SET button to make the **REC OUT SET** indication disappear. The signals of the program source being listened to or watched are output from the recording output jacks.

Monitoring while recording

When you use a 3-head tape recorder, you can monitor the recorded result.

1 Select a program source for recording with an input select button.

2 Press the SET button. **REC OUT SET** appears in the display.

3 Select the tape deck to be used for recording (TAPE1, TAPE2 etc.). You can monitor the recorded result now.

*At this time, if you select a digital program source, the signal is output to the digital REC OUT jack only; recording should be made with digital equipment. No signal is output to analog AUDIO OUT or REC OUT jacks.

Using the Remote Commander

The remote commander supplied learns various functions of other remote control units that use infrared rays, allowing you to control most of audio and video equipment from a distance.

When operating Sony equipment, you have only to press the button designated as LDP (laser disc player), TUNER, TAPE, etc. Of course, regardless of these designations, you can store the functions of Sony equipment in other buttons of the remote commander in the same way as explained.

First, store the other manufacturer's operating codes in your remote commander supplied. You can freely store any function in any button, but to make the relationship between the functions and buttons clear, make a note of which functions are assigned to which buttons.

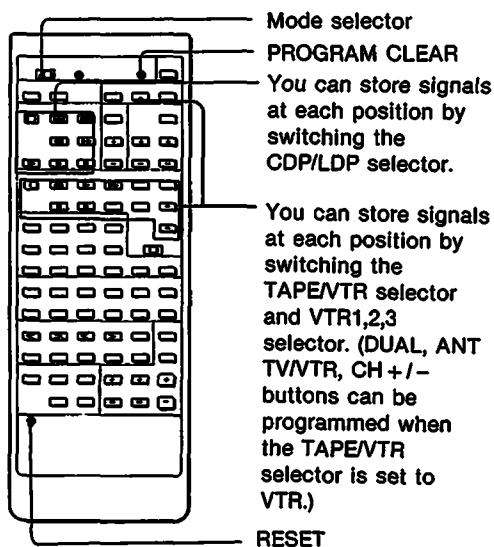

You can use the VTR1, 2, 3 selector when the TAPE/VTR selector is set to VTR.

Up to six VCRs can be remotely controlled combining the VTR1,2 3 selector and the mode selector.

For example, you can operate three Sony VCRs with the VTR1, 2 3 selector when the mode selector is set to SONY STD, and you can operate three VCRs from other manufacturers with the VTR1, 2, 3 selector when the mode selector is set to USER STD.

Storing Signals

Point the heads of both remote control units towards each other.

Don't move either during the following operation.

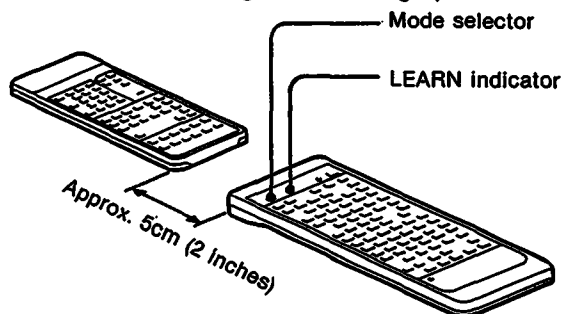

1 Set the mode selector to LEARN.

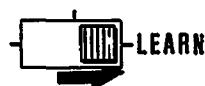

2 Press and hold the button of the remote commander supplied with this amplifier where the signal is to be stored.

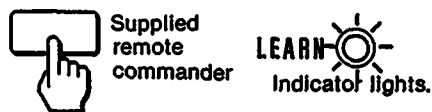

3 Press the button of the other manufacturer's remote control unit.

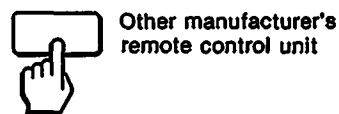

4 Remove your fingers from both control units when the LEARN lamp goes out. If the indicator blinks, start again from step 2.

5 Repeat steps 2 to 4 when you want to store another signal.

6 Set the mode selector to USER STD or SONY STD.



Controlling Equipment

Mode selector

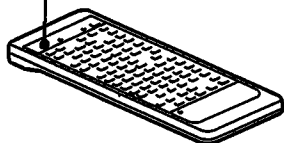

To control Sony equipment
Set the mode selector to SONY STD.



To control equipment with stored signals
Set the mode selector to USER STD.



To clear all the stored signals

- 1** Set the mode selector to LEARN.
- 2** Press and hold any button of the programmable area until the LEARN indicator lights up.
- 3** Keep pressing the PROGRAM CLEAR button with something small such as ball-point pen until the LEARN indicator goes out.

To store a new signal in a previously stored button

- 1** Set the mode selector to LEARN.
- 2** Store the signal in the same way as described. The previously stored signal is erased and the new signal is stored.

The number of signals which can be stored depends on the format of the signal. If you store signals for Sony equipment, approximately ninety signals can be stored. If the batteries in the other remote control unit are nearly exhausted, the number of storable signals is reduced or storing may become difficult (the LEARN indicator will blink).

Other manufacturer's equipment which can be remotely controlled

The equipment should be designed for use with a wireless remote control unit that uses infrared rays. Since the remote commander supplied can only "learn" signals emitted from another remote control unit, it cannot control equipment that does not use a remote control unit. The commander cannot learn some particular signals. Be sure to test if the equipment really works with the supplied remote commander after storing signals.

Do not attempt to use the remote commander with an air conditioner or other household appliances.

Note on REC button

The REC button should be pressed together with the button on its right when storing a signal as well as when it is actually being used. The REC button does not work alone.

When the LEARN indicator does not light even though a button is pressed

The batteries are almost exhausted. The remote commander can no longer operate the unit nor store signals. Replace both batteries with new ones.

When the equipment works incorrectly

Press the RESET button and proceed again. The stored signals are not erased even though you press the RESET button.

When Sony equipment works incorrectly

Store the signals in the same way as for equipment from other manufacturers. In this case, the mode selector should be set to USER STD.

When no signals have been stored

Sony equipment can be remotely controlled even when the mode selector is set to USER STD.

Table of Factory-preset Parameters

Parameter	1	2	3	4	5	6	7	8	9	10	
SOUNDFIELD	HALL1	HALL2	OPERA	CHURCH	JAZZ CLUB	DISCO	STADIUM	THEATER1	THEATER2	DOLBY SURROUND	
Room Size	1.0	1.0	1.0	1.0	1.0	1.0	1.0	1.0	1.0		
Wall	1.0	1.2	1.1	1.8	1.7	1.0	0.7	0.8	0.8		
Seat Position (Rear-Front/Left-Right)	F20/0	F20/0	F20/0	F20/0	F20/0	0/0	F20/0	R5/0	R5/0		
Center Level	The level preset in PRESET will be recalled.										
Rear Level	The level preset in PRESET will be recalled.										
Band1	Level	+0.3dB	+0.6dB	+0.6dB	+0.9dB	+0.8dB	-5.0dB	+2.3dB	+2.2dB	+0.3dB	0dB
	Frequency	99Hz	78Hz	115Hz	99Hz	85Hz	21Hz	85Hz	78Hz	78Hz	99Hz
	Equalizer Slope(Q)	0.7	0.7	0.7	0.7	1.3	1.3	1.3	0.5	0.5	0.7
Band2	Level	0dB	0dB	+0.5dB	0dB	+0.3dB	+10.5dB	0dB	0dB	+1.9dB	0dB
	Frequency	1.00kHz	1.00kHz	734Hz	1.00kHz	793Hz	67Hz	1.00kHz	1.00kHz	734Hz	1.00kHz
	Equalizer Slope(Q)	0.7	0.7	0.7	0.7	0.7	1.3	0.7	0.5	0.8	0.7
Band3	Level	0dB	0dB	-0.3dB	+0.3dB	-0.3dB	+7.5dB	0dB	-3.7dB	-3.7dB	0dB
	Frequency	8.00kHz	8.00kHz	16.0kHz	14.8kHz	20.0kHz	4.32kHz	8.00kHz	10.0kHz	10.0kHz	8.00kHz
	Equalizer Slope(Q)	0.7	0.7	0.7	0.7	0.7	1.3	0.7	0.5	0.5	0.7
Effect Level	70%	70%	70%	70%	70%	70%	70%	70%	70%		
Early Reflection Time	26mS	32mS	38mS	98mS	20mS	14mS	250mS	30mS	18mS		
Early Reflection Level	80%	80%	80%	65%			80%				
Reverb Time	2.2sec	2.5sec	1.8sec	2.6sec			2.0sec				
PRO LOGIC DECODER	OFF	OFF	OFF	OFF	OFF	OFF	OFF	ON	ON		
Separation Control	10	10	10	10	10	10	10	10	10	10	
Dynamics	OFF	OFF	OFF	OFF	OFF	CMP3	OFF	CMP3	CMP3	OFF	
Delay Time (Rear Left Channel/Right Channel)										20.0mS 20.0mS	

- Band1, 2, 3 of the preset numbers 1 to 7 are the values of FRONT and REAR.
- Band1, 2, 3 of the preset numbers 8 and 9 are the values of FRONT and CENTER, and the value of REAR is flat.
- Band1, 2, 3 of the preset number 10 are the values of FRONT CENTER and REAR.

Specifications

Amplifier section

Frequency response (Parametric EQ, Dynamics, Surround: OFF)

Other than PHONO
Front, Center*, Rear:
10 Hz-20kHz \pm 0.1dB
Subwoofer: Cut off 80Hz, 18dB/oct.

PHONO
VIDEO 1-3 AUDIO OUT, TAPE1, 2
REC OUT: 20Hz-20kHz \pm 0.2dB

Input sensitivity and input impedance

PHONO (MM): 5mV, 50kohms
TUNER, CD, TAPE1, 2, VIDEO 1-5,
LD, TV: 250mV, 50kohms
DIGITAL OPTICAL 1, 2: None
DIGITAL COAXIAL: 0.5Vp-p \pm 20%
75ohms

S/N

PHONO
Front, Center, Rear: 84dB (A)
TUNER, CD, TAPE1, 2, VIDEO 1-5,
LD, TV
Front, Center, Rear: 94dB (A)
DIGITAL (OPTICAL 1, 2, COAXIAL)
Front, Center, Rear: 103dB (A)

Remaining noise

Below 10 μ V (A)

Output voltage and output impedance

VIDEO 1-3 AUDIO OUT, TAPE, 1, 2
REC OUT: 250mV, 470 ohms
FRONT, CENTER, REAR,
SUBWOOFER: 2.5V
DIGITAL OPTICAL 2: None
DIGITAL COAXIAL: 0.5Vp-p \pm 20%,
75 ohms
HEADPHONES: 25mW (at 8 ohms);
accepts low and high impedance
headphones

Total harmonic distortion

Analog input
Front: below 0.004% at 1kHz
Digital input
Front: below 0.003% at 1kHz

*When the PRO LOGIC MODE button is set to WIDE in Dolby SURROUND Mode.

Video section

Video input sensitivity and input impedance

VIDEO IN
VIDEO 1-5, LD, TV: 1Vp-p, 75ohms
S VIDEO IN
VIDEO1, 2, 5
Luminance (Y): 1Vp-p, 75ohms
Chroma (C): 0.286Vp-p, 75ohms

Video output voltage and output impedance

VIDEO OUT
VIDEO 1-3, MONITOR1, 2: 1Vp-p,
75ohms
S VIDEO OUT
VIDEO 1, 2, MONITOR
Luminance (Y): 1Vp-p, 75ohms
Chroma (C): 0.286Vp-p, 75ohms

Digital signal processor section

Parametric equalizer 3-band
center frequency: 18Hz-20kHz, 1/9
oct.-step
Level: \pm 12dB, 0.1dB-step
Slope (Q): 16-steps
Dynamics Compressor: 1-9, 1-step
Expander: 1-9, 1-step
Surround Main parameter
Room size: 0.5-2.0, 0.1-step
Wall: 0.5-2.0, 0.1-step
Seat position: F50-0-R50, L50-0-R50
1-step
Sub parameter
Early reflection time: 2-500mS**
2mS-step
Early reflection level: 0-100%,
1%-step
Reverb time: 0.3-5.0S 0.1S-step
PRO LOGIC DECODER: ON, OFF
Separation control: 0-10, 1-step
Effect level: 0-100%, 1%-step
Delay time: 15.0-30.0mS,
0.1mS-step

**When Room = 2.0, this is adjustable up to 500mS

A/D, D/A converter section

A/D converter Type: High density linear converter
system
D/A converter Sampling frequency: 48kHz
Front: Advanced pulse D/A converter
system
Center: Advanced pulse D/A
converter
Rear: Advanced pulse D/A converter
Sampling frequency: 32kHz, 44.1kHz,
48kHz

General

Power requirements AC 120V, 60Hz
Power consumption 38 watts
AC outlets Three switched, total 720 watts
One unswitched, 240 watts
Dimensions Approx. 470 x 150 x 355 mm
(18½ x 6 x 14 inches) (w/h/d)
including projecting parts and
controls.
Weight Width when removing the side
panels: 430mm (17 inches)
Approx. 8.5 kg (18 lb 12oz)
Supplied accessories Programmable remote commander
RM-P2000 (1)
Sony Batteries SUM-3 (NS) (2)
Audio connecting cord (3)
Screw (4)
Ferrite core (1)

Design and specifications are subject to change without notice:

Block Diagram

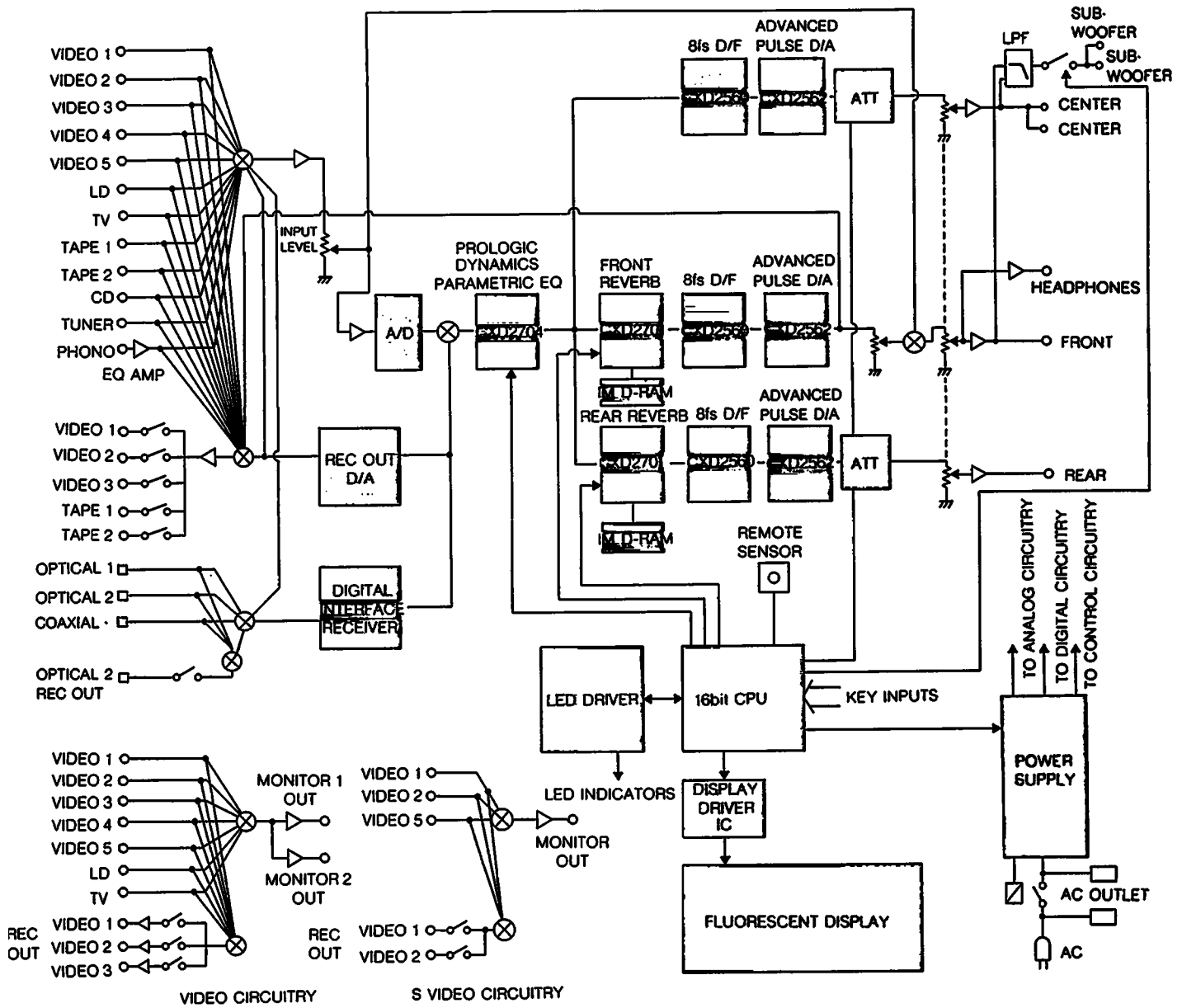

Messages in the Display

The following messages will appear in the display to notify you that you have attempted to operate the amplifier incorrectly.

Can not use

- Appears when you press the EFFECT REC button while SOURCE DIRECT has been already pressed. The EFFECT REC button should be pressed when digitally-processed sounds are to be recorded.
- Appears when you press the SET button while EFFECT REC has been already pressed. The SET button should be pressed when a program source is to be recorded while you are listening to or watching another program source.
- Appears when you press the EFFECT REC button while the REC OUT SET indication has already appeared. The EFFECT REC button should be pressed when digitally-processed sounds are to be recorded.
- Appears when you press the CHARACTER button to change the title of a sound field which was preset at the factory. The titles of the sound fields preset at the factory are fixed and cannot be changed.
- Appears when you press the TEST TONE button in a mode other than DOLBY SUR. You can hear the test tone only in DOLBY SUR. mode

Visual only

Appears when you press an input select button from TAPE1 to DIGITAL which does not have a video signal while the **VISUAL** ◀ indication appears for mixing operation.

An input select button from VIDEO1 to TV which does have a video signal should be pressed while **VISUAL** ◀ appears.

“Dynamics off” flashes

When you try to adjust dynamics while the DYNAMICS indicator is not lit.

“Equalizer off” flashes

When you try to adjust parametric equalizer while the PARAMETRIC EQ indicator is not lit.

“Surround off” flashes

When you try to adjust surround while the SURROUND indicator is not lit.

Troubleshooting Guide

Before proceeding through the check list below, examine the connections and the procedures outlined in the manual. Should any problems persist after you have checked the following items, consult your nearest Sony dealer.

Symptom	Cause and remedy
Power cannot be turned on.	The AC power cord is disconnected from a wall outlet.
No sound is heard.	The program source equipment is not connected correctly.
	The program source equipment is not turned on.
	Speaker terminals on the power amplifier are short-circuited.
	You have pressed the wrong input select button.
	You try to play back an analog program source while a digital input is assigned to the input select button. —Reset the assignment, or connect an appropriate digital program source to the digital input jack.
	You have pressed the MUTING button. —Press the button to disengage.
	The DIGITAL/ANALOG input level is set to minimum. —Adjust the input level correctly.
No sound or sound at very low level is heard from rear speakers.	The SURROUND function is turned off.
	The output level of the rear speakers is set to $-\infty$ dB.
	A monaural program source is being played back in Dolby surround mode.
	The PRO LOGIC MODE button is set to 3CH. LOGIC.
No sound is heard from one channel.	The BALANCE control is not set properly.
	A speaker cord or connecting cord is disconnected.
Sound is distorted.	Output level is higher than the capacity of the speakers. The OVER indication has appeared.
Instrument disposition is obscure or there is lack of bass sound.	The speaker connections are not correct. —The connections should be made with the “+” to “+” and “-” to “-”.
Hum or noise is heard.	The earth connection of the turntable is loose.
	A connecting cord is not connected firmly.
No picture is seen.	The connection is not correct.
	The input selection is not correct.
Picture is unclear or poor.	You have placed the amplifier near a device which might generate noise.

Audio

Video

	Symptom	Cause and remedy
Remote Commander	Remote commander does not operate.	The batteries are not inserted correctly. There is an obstacle between the commander and the amplifier. The batteries are exhausted. The mode selector is not set to USER STD despite the fact that you want to control the amplifier with stored signals.
	No signal is stored.	The two remote control units are located near something which might generate noise, such as a fluorescent lamp. The batteries of the remote commander supplied or the other manufacturer's remote control unit are exhausted.
	LEARN indicator does not light even though any button is pressed.	The batteries are exhausted.
	LEARN indicator goes out after flashing	The internal memory capacity is full.
Indication	Indication is incorrect.	This is caused by external noise or static electricity. Disconnect the AC power cord and wait for a while, then connect it again.
Operation	Function of buttons is not accepted.	This is caused by external noise or static electricity. Disconnect the AC power cord and wait for a while, then connect it again.